

**CUPERTINO SANITARY DISTRICT
SANITARY BOARD MEETING
WEDNESDAY, OCTOBER 5, 2022**

AGENDA

The meeting will be held at 7:00 p.m. via teleconference [call 1 (866) 899 - 4679 Conference Access Code: 251566821] and anyone interested may also call in. The District Office at 20863 Stevens Creek Blvd, Suite 100, Cupertino is closed.

1. ROLL CALL

2. AB 361

The Board of Directors makes the following findings required by AB 361 in order to continue holding meetings by teleconferencing electronically: (1) the March 4, 2020 Governor's Proclamation of a State of Emergency is still in effect, (2) the California Department of Public Health and the County Health Officer continue to encourage social distancing and strongly recommend that all people wear masks in all indoor public spaces, and (3) due to room capacity limitations, meeting in person would present imminent risks to the health or safety of attendees.

3. PUBLIC COMMENTS

This portion of the meeting is reserved for persons desiring to address the board on any matter not on the agenda. Speakers are limited to three (3) minutes.

All statements requiring a response will be referred to staff for further action. In most cases, state law will prohibit the board from making any decisions with respect to a matter not listed on the agenda.

4. CLOSED SESSION

- A. CONFERENCE WITH LEGAL COUNSEL – EXISTING LITIGATION
in accordance with government code section Paragraph (1) of Subdivision (d) of Section 54956.9, existing litigation. Name of Case: County Sanitation District 2-3, West Valley Sanitation District, Cupertino Sanitary District, Burbank Sanitary District and the City of Milpitas v. The City of San Jose, The City of Santa Clara and Does 1 through 50 inclusive.

5. MINUTES

- A. APPROVAL OF THE REGULAR MEETING MINUTES OF SEPTEMBER 21, 2022
- B. APPROVED MINUTES OF AUGUST 17, 2022

6. CORRESPONDENCE

NONE

**CUPERTINO SANITARY DISTRICT
SANITARY BOARD MEETING
WEDNESDAY, OCTOBER 5, 2022**

7. MEETINGS

- A. TELECONFERENCE MEETING OF THE SAN JOSE/SANTA CLARA TREATMENT PLANT TECHNICAL ADVISORY COMMITTEE (TAC) TO BE HELD ON MONDAY, OCTOBER 10, 2022 IS CANCELED
- B. TELECONFERENCE MEETING OF THE SAN JOSE/SANTA CLARA TREATMENT PLANT ADVISORY COMMITTEE (TPAC) HELD ON THURSDAY, OCTOBER 13, 2022 IS CANCELED
- C. CALIFORNIA ALLIANCE FOR SEWER SYSTEM EXCELLENCE (CASSE) IN-PERSON GENERAL MEETING HOSTED BY SACRAMENTO AREA SEWER DISTRICT TO BE HELD OCTOBER 6, 2022 IN SACRAMENTO, CA

8. REPORTS

NONE

9. UNFINISHED BUSINESS

- A. VALLCO INSTALLER'S AGREEMENT
- B. WATER LOSS CALCULATION DISCUSSION
- C. COVID-19 UPDATES

10. NEW BUSINESS

- A. SIGNIFICANT DEFECT REPAIR PROJECT – AUTHORIZATION TO BID

11. STAFF REPORT

- A. FUTURE DEVELOPMENT PROJECTS
- B. FALL FESTIVAL

12. CALENDAR ITEMS

- A. NEXT REGULAR DISTRICT BOARD MEETING IS SCHEDULED TO BE HELD ON WEDNESDAY, OCTOBER 19, 2022

13. ADJOURNMENT

CUPERTINO SANITARY DISTRICT BOARD MEETING WEDNESDAY, SEPTEMBER 21, 2022

The Sanitary Board of the Cupertino Sanitary District convened this date at 7:00 p.m. This meeting was conducted via teleconferencing in accordance with AB 361. The District office at 20863 Stevens Creek Blvd, Suite 100, Cupertino was closed.

1. ROLL CALL:

President Bosworth called the meeting to order, and the following proceedings were had to wit: Roll call was taken, with the following members in attendance:

Directors present: William A. Bosworth, Angela S. Chen, Taghi S. Saadati, David A. Doyle, and Patrick S. Kwok.

Staff present: District Manager Benjamin Porter, Sr. Sanitary Engineer Vani Kathula, and Counsel Marc Hynes.

District Consultant: Richard K. Tanaka

Public: None

2. AB 361:

The Board of Directors makes the following findings required by AB 361 in order to continue holding meetings by teleconferencing electronically: (1) the March 4, 2020 Governor's Proclamation of a State of Emergency is still in effect, (2) the County of Santa Clara Health Officer announced on May 10, 2022 that COVID-19 cases are rising again to higher levels than last summer's surge and there is a rise in hospitalizations; she continues to encourage social distancing and advises people wear masks indoors, and (3) due to room capacity limitations, meeting in person would present imminent risks to the health or safety of attendees.

On a motion by President Bosworth, seconded by Director Kwok, by a vote of 5-0-0, the Board approved.

3. PUBLIC COMMENTS:

There were none.

4. CLOSED SESSION:

President Bosworth adjourned the regular meeting session and opened the closed session at 7:01 p.m. Manager Porter, and Sr. Engineer Kathula were excused from the closed session.

A. Conference with legal counsel – Existing Litigation in accordance with government code section Paragraph (1) of Subdivision (d) of Section 54956.9, existing litigation. Name of Case: County Sanitation District 2-3, West Valley Sanitation District, Cupertino Sanitary District, Burbank Sanitary District, and the City of Milpitas v. The City of San Jose, The City of Santa Clara, and Does 1 through 50 inclusive.

Board action: There was no reportable action.

CUPERTINO SANITARY DISTRICT BOARD MEETING
WEDNESDAY, SEPTEMBER 21, 2022

President Bosworth adjourned the closed session at 7:19 p.m. and the regular meeting was called to order. District Manager Porter, and Sr. Engineer Kathula rejoined the regular meeting.

5. MINUTES & BILLS:

- A. On a motion by Director Chen, seconded by Director Saadati, by a vote of 5-0-0, the minutes of the regular meeting held Wednesday, August 17, 2022, were approved.
- B. By consensus, the Minutes of Wednesday, August 3, 2022, are to be Noted & Filed.
- C. The Board reviewed August payable warrants and financial statements. Staff provided detailed clarification to the Board regarding the District's share of cost towards the operation and maintenance of Santa Clara Outfall. On a motion by Director Chen, seconded by President Bosworth, by a vote of 5-0-0, the financial statements and payment of bills for August were approved as written.
- D. Board members submitted their September timesheets to Manager Porter.

6. CORRESPONDENCE:

- A. The Board reviewed an email from California Special Districts Association - Initiative #21-0042A1 (CBRT Initiative). Board reviewed the email, the initiative, and Resolution 1340 to oppose the initiative. On a motion by President Bosworth, seconded by Director Saadati, by a vote of 5-0-0, the Board approved Resolution 1340 to oppose the CBRT initiative #21-0042A1.
- B. The Board reviewed an email from California Association Of Sanitation Agencies (CASA) – AB 2247 (Bloom) - Letters of Support Needed. On a motion by President Bosworth, seconded by Director Kwok, by a vote of 5-0-0, the Board approved motion to submit a letter of support.
- C. The Board reviewed a letter from a senior resident requesting senior exemption of sewer service charges. On motion by Director Kwok, second by Director Chen, by a vote of 5-0-0, the request of the resident to exempt the sewer service charges was denied.
- D. The Board reviewed an email from Local Agency Formation Commission of Santa Clara County (LAFCO) Sphere of Influence – Lawrence-Mitty USA/SOI. It is to be Noted & Filed.

7. MEETINGS:

- A. Manager Porter plans to attend the teleconference meeting of The San Jose/Santa Clara Treatment Plant Technical Committee (TAC) to be held on Monday, October 10, 2022.
- B. Director Kwok plans to attend the teleconference meeting of The San Jose/Santa Clara Treatment Plant Advisory Committee (TPAC) to be held on Thursday, October 13, 2022.

CUPERTINO SANITARY DISTRICT BOARD MEETING
WEDNESDAY, SEPTEMBER 21, 2022

8. REPORTS:

- A. Manager Porter reported on the teleconference meeting of The San Jose/Santa Clara Treatment Plant Technical Advisory Committee (TAC) held on Monday, September 5, 2022.
- B. Director Kwok reported on the teleconference meeting of The San Jose/Santa Clara Treatment Plant Advisory Committee (TPAC) held on Thursday, September 8, 2022.
- C. President Bosworth reported on the teleconference meeting of The Santa Clara County Special Districts Association held on Monday, September 12, 2022.

9. UNFINISHED BUSINESS:

- A. District Manager Porter reported on the Covid-19 updates.
- B. District Manager Porter and Staff will attend the District public outreach booth at the Cupertino Fall Festival, to be held on Saturday, September 24, 2022.

10. NEW BUSINESS:

- A. The Board reviewed the Board Memo requesting Purchase of CUES Inc. lateral camera and GraniteNet software. On motion by Director Kwok, seconded by Director Chen, by a vote of 5-0-0, the Board approved the purchase of the lateral camera and software in the amount of \$21,490.06.

11. STAFF REPORTS:

- A. Manager Porter reported on Future Development Projects.
- B. Manager Porter reported on Ethics Training Certificate update.
- C. Manager Porter reported on the Monthly Maintenance Summary and District repairs. District maintenance is ahead of schedule for mainline cleaning and on schedule for FOG inspections and other maintenance activities.

12. CALENDAR ITEMS:

- A. The next regular District Board meeting is scheduled to be held on Wednesday, October 5, 2022.
 - a) President Bosworth and Director Kwok are excused from the regular Board meeting of October 19, 2022.
 - b) The regular Board meeting of November 2, 2022 is cancelled due to three Board members scheduled to be away.

13. ADJOURNMENT:

On a motion properly made and seconded, at 8:35 p.m. the meeting was adjourned.

Secretary of the Sanitary Board

President of the Sanitary Board

CUPERTINO SANITARY DISTRICT BOARD MEETING
WEDNESDAY, AUGUST 17, 2022

The Sanitary Board of the Cupertino Sanitary District convened this date at 7:02 p.m. This meeting was conducted via teleconferencing in accordance with AB 361. The District office at 20863 Stevens Creek Blvd, Suite 100, Cupertino was closed.

1. ROLL CALL:

President Bosworth called the meeting to order, and the following proceedings were had to wit: Roll call was taken, with the following members in attendance:

Directors present: William A. Bosworth, Angela S. Chen, Taghi S. Saadati, and David A. Doyle. Patrick S. Kwok was in and out of the meeting due to technical issues.

Staff present: District Manager Benjamin Porter, Deputy District Manager Robert Woodhouse, and Counsel Marc Hynes.

District Consultant: Richard K. Tanaka

Public: None

2. AB 361:

The Board of Directors makes the following findings required by AB 361 in order to continue holding meetings by teleconferencing electronically: (1) the March 4, 2020 Governor's Proclamation of a State of Emergency is still in effect, (2) the County of Santa Clara Health Officer announced on May 10, 2022 that COVID-19 cases are rising again to higher levels than last summer's surge and there is a rise in hospitalizations; she continues to encourage social distancing and advises people wear masks indoors, and (3) due to room capacity limitations, meeting in person would present imminent risks to the health or safety of attendees.

On a motion by President Bosworth, seconded by Director Chen, by a vote of 4-0-0, the Board approved. Director Kwok was not present for the vote.

3. PUBLIC COMMENTS:

There were none.

4. CLOSED SESSION:

President Bosworth adjourned the regular meeting session and opened the closed session at 7:04 p.m. Manager Porter, and Deputy Manager Woodhouse were excused from the closed session.

A. Conference with legal counsel – Existing Litigation in accordance with government code section Paragraph (1) of Subdivision (d) of Section 54956.9, existing litigation. Name of Case: County Sanitation District 2-3, West Valley Sanitation District, Cupertino Sanitary District, Burbank Sanitary District, and the City of Milpitas v. The City of San Jose, The City of Santa Clara, and Does 1 through 50 inclusive.

Board action: There was no reportable action.

CUPERTINO SANITARY DISTRICT BOARD MEETING
WEDNESDAY, AUGUST 17, 2022

President Bosworth adjourned the closed session at 7:29 p.m. and the regular meeting was called to order. District Manager Porter, and Deputy District Manager Woodhouse rejoined the regular meeting.

5. MINUTES & BILLS:

- A. On a motion by Director Chen, seconded by Director Doyle, by a vote of 4-0-0, the minutes of the regular meeting held Wednesday, August 3, 2022, were approved. Director Kwok was not present for the vote.
- B. By consensus, the Minutes of Monday, July 20, 2022, are to be Noted & Filed.
- C. The Board reviewed July payable warrants and financial statements. On a motion by Director Saadati, seconded by Director Chen, by a vote of 5-0-0, the financial statements and payment of bills were approved as written.
- D. Board members will submit their August timesheets to Manager Porter.

6. CORRESPONDENCE:

- A. The Board reviewed a letter from LAFCO, titled Adopted FY22-23 LAFCO Budget. It is to be Noted & Filed.

7. MEETINGS:

- A. Manager Porter and Advisor Tanaka both plan to attend the teleconference meeting of The San Jose/Santa Clara Treatment Plant Technical Committee (TAC) to be held on Monday, September 5, 2022.
- B. Director Kwok plans to attend the teleconference meeting of The San Jose/Santa Clara Treatment Plant Advisory Committee (TPAC) to be held on Thursday, September 8, 2022.
- C. Added to the agenda: Director Bosworth plans to attend the Santa Clara County Special District meeting to be held on September 12, 2022.

8. REPORTS:

- A. Manager Porter reported on the teleconference meeting of The San Jose/Santa Clara Treatment Plant Technical Advisory Committee (TAC) held on Monday, August 8, 2022.
- B. Deputy Manager Woodhouse reported on the California Alliance for Sewer System Excellence (CASSE) teleconference meeting held on Wednesday, August 10, 2022.

CUPERTINO SANITARY DISTRICT BOARD MEETING
WEDNESDAY, AUGUST 17, 2022

- C. Directors Kwok and Chen reported on the teleconference meeting of The San Jose/Santa Clara Treatment Plant Advisory Committee (TPAC) held on Thursday, August 11, 2022.
- D. Directors Chen, Kwok and Saadati reported on the CSRMA training held on August 10, 2022 in Olympic Valley, CA.
- E. The Board attended the California Association of Sanitation Agencies (CASA) annual conference held August 10-12, 2022 in Olympic Valley, CA.
 - 1. Director Chen reported on the CSRMA Board of Directors meeting.
 - 2. Counsel Hynes reported on the Attorney's Committee meeting.
 - 3. Other conference sessions:
 - Consider adding link on the District website to information about non-flushable wipes.
 - SSMP audit needs to be certified every two years.
 - Consider investigating the Cybersecurity assessment, which is free of charge.

9. UNFINISHED BUSINESS:

- A. The Board reviewed the VTA Utility Agreement for the Wolfe Road Sewer Relocation Project. On motion by Director Saadati, seconded by Director Doyle, by a vote of 5-0-0, the Board approved the agreement as written.
- B. The Board reviewed and discussed the Conflict-of-Interest code. On motion by President Bosworth, seconded by Director Chen, by a vote of 5-0-0, the Board determined that no changes needed to be made to the Conflict-of-Interest Code.
- C. The Board discussed Ethics Certificate Renewal.
- D. There were no Covid-19 updates.

10. NEW BUSINESS:

- A. The Board reviewed the Board Memo requesting Purchase of New Multiquip Trailer Mounted Generator. On motion by President Bosworth, seconded by Director Chen, by a vote of 5-0-0, the Board approved the purchase of a new generator.

CUPERTINO SANITARY DISTRICT BOARD MEETING
WEDNESDAY, AUGUST 17, 2022

11. STAFF REPORTS:

- A. Manager Porter reported on Future Development Projects.
- B. Manager Porter reported on the Monthly Maintenance Summary.

12. CALENDAR ITEMS:

- A. The next regular District Board meeting is scheduled to be held on Wednesday, September 7, 2022.

13. ADJOURNMENT:

On a motion properly made and seconded, at 9:07 p.m. the meeting was adjourned.

Secretary of the Sanitary Board

President of the Sanitary Board



CALIFORNIA ALLIANCE FOR SEWER SYSTEM EXCELLENCE

Date: October 6, 2022

Sacramento Area Sewer District • 10060 Goethe Road, Sacramento, CA 95827

Agenda		
Session	Time	Activity
I.	10:00 a.m.	Welcome
	10:15 a.m.	CARB's Advanced Clean Fleet Regulations – <i>Presentation by Steve Jepsen, Executive Director, Southern California Alliance of POTWs</i>
	11:15 a.m.	Commercial Driver's License Requirements – <i>Roundtable discussion on what agencies are doing to meet requirements</i>
II.	11:45 a.m.	Lunch Break
	12:30 p.m.	WDR Update – <i>Roundtable discussion on agency perspectives on implementation and new updates. Discussion led by Steve Jepsen, Ed Oyama, and Bob Woodhouse</i>
	1:30 p.m.	OC San Technology Applications for Gravity Sewers – <i>Presentation by Don Stokes, OC San</i> OC San has applied technology to address the following <ul style="list-style-type: none"> – Condition-based maintenance: using data to drive cleaning frequencies – Early SSO warning – Chemical dosing optimization and hydrogen sulfide management
III.	2:15 p.m.	Break
	2:30 p.m.	COVID – <i>Roundtable Discussion</i> <ul style="list-style-type: none"> – Telework practices and policies – Vaccine and mask mandates <ul style="list-style-type: none"> o Enforcement practices for mandates – Maintenance Activities <ul style="list-style-type: none"> o What challenges have agencies experienced with maintenance and operations activities o What new maintenance actions/practices have agencies implemented during COVID
	3:00 p.m.	What is currently driving SSOs? – <i>Roundtable Discussion</i> <ul style="list-style-type: none"> – Are SSOs increasing or decreasing? – What were the contributing factors?
	3:30 p.m.	Meeting Ends

Item 10.A.

Significant Defect Repair Project

9/30/2022

				Engineer's Estimate	
Line Item	Description	Unit	Quantity	Unit Price	Total Cost
Project Wide					
1	Mobilization	LS	1	\$ 6,004.20	\$ 6,004.20
2	Water Pollution Control	LS	1	\$ 10,007.00	\$ 10,007.00
3	Site Clearing	LS	1	\$ 5,003.50	\$ 5,003.50
4	Traffic Control	LS	1	\$ 10,007.00	\$ 10,007.00
				Sub-Total =	\$ 31,021.70
Location 1: Segment 30000303, at Depth 10 feet on Mercedes Road					
6	Remove and Replace 11 LF of 6" VCP with 11 LF of 6" PVC SDR 26.	LF	11	\$ 450.00	\$ 4,950.00
7	Reconnect New 6" PVC into MH T-73 on Mercedes Road	LS	1	\$ 1,300.00	\$ 1,300.00
				Sub-Total =	\$ 6,250.00
Location 2: Segment 300001236, at Depth 11 feet on Cordova Road					
8	Remove and Replace 18 LF of 6" VCP with 18 LF of 6" PVC SDR 26.	LF	18	\$ 450.00	\$ 8,100.00
9	Install new 6"x4" Wye.	EA	1	\$ 2,000.00	\$ 2,000.00
10	Remove and Replace 24 LF of 6" VCP with 24 LF of 6" PVC SDR 26.	LF	24	\$ 350.00	\$ 8,400.00
11	Remove and Replace 6 LF of 6" VCP with 6 LF of 6" PVC SDR 26.	LF	6	\$ 650.00	\$ 3,900.00
12	Install new 6"x4" wye	EA	1	\$ 2,000.00	\$ 2,000.00
13	Reconnect New 24 LF of 6" PVC into FI L2-FF	LS	1	\$ 1,300.00	\$ 1,300.00
				Sub-Total =	\$ 25,700.00
Location 3: Segment 30000540, at Depth 9 feet on San Felipe Road					
14	Remove and Replace 10 LF of 6" VCP with 10 LF of 6" PVC SDR 26.	LF	10	\$ 550.00	\$ 5,500.00
15	Reinstate two new 6"x4" Wyes.	EA	2	\$ 2,000.00	\$ 4,000.00
16	Remove and Replace 6 LF of 6" VCP with 6 LF of 6" PVC SDR 26.	LF	6	\$ 650.00	\$ 3,900.00
17	Repair concrete curb and gutter per City of Cupertino standard. Cut and replace from nearest joint to joint	LS	1	\$ 2,000.00	\$ 2,000.00
				Sub-Total =	\$ 15,400.00
Location 4: Segment 30000704, at Depth 7 feet on Fountainbleu Apartment Easement					
18	Remove and Replace 11 LF of 8" VCP with 11 LF of 8" PVC SDR 26.	LF	11	\$ 500.00	\$ 5,500.00
19	Reinstate one new 4"x8" Wye	EA	1	\$ 2,000.00	\$ 2,000.00
20	Reconnect replaced pipe to MH T-85	LS	1	\$ 1,300.00	\$ 1,300.00
				Sub-Total =	\$ 8,800.00
Location 8: Segment 300003145, at Depth 8 feet on Arroyo De Arguello Easement					
21	Remove and Replace 18 LF of 8" Cast Iron with 18 LF of 8" PVC SDR 26.	LF	18	\$ 500.00	\$ 9,000.00
22	Reinstate or Reconnect lateral with new 6"x4" Wye.	EA	1	\$ 2,000.00	\$ 2,000.00
23	Abandon in place Exist. 153 LF of 8" Cast Iron	LF	153	\$ 40.00	\$ 6,120.00
24	Remove Exist FI 4828-1F SEE detail sheet SD-1	LS	1	\$ 1,000.00	\$ 1,000.00
				Sub-Total =	\$ 18,120.00
Location 11: Segment 300001464, at Depth 6 feet on Vaquero Court (Private Road)					
25	Remove and Replace 6 LF of 8" VCP with 6 LF of 8" PVC SDR26.	LF	6	\$ 700.00	\$ 4,200.00
				Sub-Total =	\$ 4,200.00
Location 12: Segment 300000669, at Depth 6 feet on Villa Oaks Easement					
26	Remove 16 LF of 6" PVC with 16 LF of 6" PVC SDR26	LF	16	\$ 450.00	\$ 7,200.00
				Sub-Total =	\$ 7,200.00
Location 13: Segment 300001469, at Depth 6 feet on Pierce Road					
27	Remove and Replace 12 LF of 8" VCP with 12 LF of 8" PVC SDR26.	LF	12	\$ 500.00	\$ 6,000.00
28	Remove and Replace 6 LF of 8" VCP with 6 LF of 8" PVC SDR26.	LF	6	\$ 700.00	\$ 4,200.00
				Sub-Total =	\$ 10,200.00
Location 14: Segment 300001496, at Depth 6 feet on Vista Regina					
29	Remove and Replace 6 LF of 8" VCP with 6 LF of 8" PVC SDR26	LF	6	\$ 700.00	\$ 4,200.00
				Sub-Total =	\$ 4,200.00
				Grand Total =	\$ 131,091.70

CUPERTINO SANITARY DISTRICT CUPERTINO, CALIFORNIA

CUSD SIGNIFICANT DEFECT REPAIR PROJECT

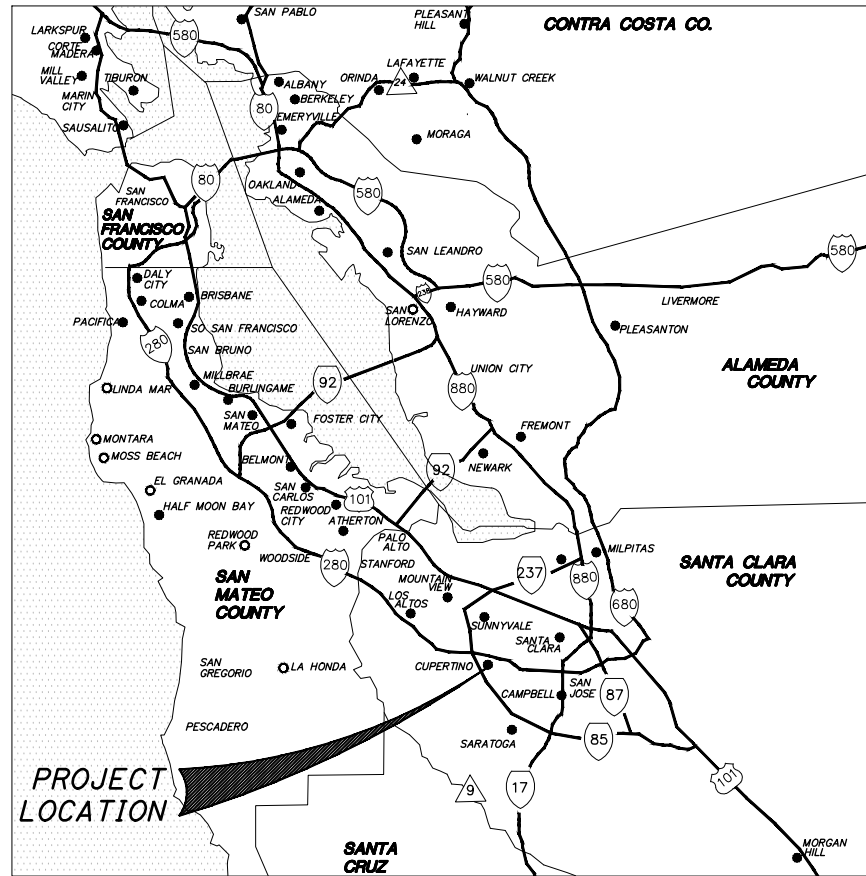

VICINITY MAP

SCALE: NTS

SHEET INDEX		
SHEET #	DESCRIPTION	SHEET NAME
1	TITLE SHEET	T-1
2	GENERAL NOTES	G-1
3-5	LAYOUT 1-3	L-1 - L-3
6-7	STANDARD DETAILS	SD-1 - SD-2
8	TRAFFIC CONTROL	TC-1

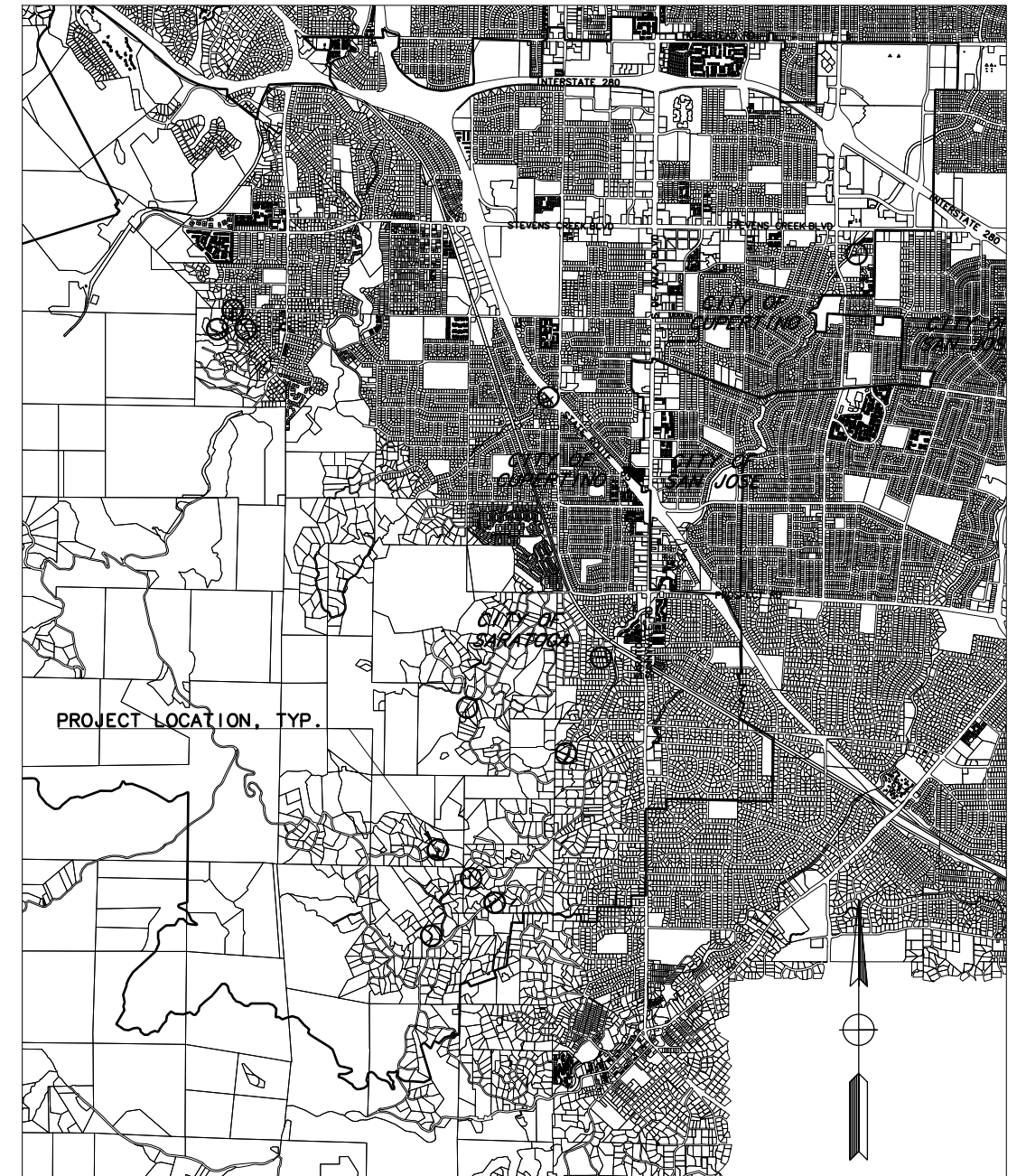

LOCATION MAP

SCALE: 1" = 2500'

65% SUBMITTAL



20863 STEVENS CREEK BLVD, STE 100
CUPERTINO, CA 95014
(408) 255-2137

DESIGNED BY :	ED			
DRAWN BY :	ED			
CHECKED BY :	BP			
DATE :	9/8/2022			
SCALE :				
MTCO JOB No. :	21-00123			

No.	DESCRIPTION	DATE	BY
REVISIONS			



CUPERTINO SANITARY DISTRICT
20863 STEVENS CREEK BOULEVARD, SUITE 100
CUPERTINO, CA 95014
(408) 255-2137 FAX (408) 253-5173

REGISTERED CIVIL ENGINEER _____ DATE _____

CUSD SIGNIFICANT DEFECT REPAIR PROJECT
TITLE SHEET

WORK ORDER No. _____ ADVERTISEMENT DATE: _____ CONTRACT No. _____

SHEET
1
OF 9 SHEETS
T-1

GENERAL NOTES

1. ALL WORK SHALL BE PERFORMED IN CONFORMANCE WITH THE FOLLOWING:
 - 1.1. PROJECT MANUAL TITLED "WOLFE ROAD SEWER RELOCATION PROJECT"
 - 1.2. APPLICABLE SECTIONS OF THE STATE OF CALIFORNIA DEPARTMENT OF TRANSPORTATION STANDARD SPECIFICATIONS, HEREIN REFERRED TO AS 'CALTRANS'.
 - 1.3. CUSD STANDARD PLANS, THESE PLANS & DETAILS, AND STANDARD SPECIFICATIONS.
2. EXISTING UNDERGROUND UTILITIES AND IMPROVEMENTS ARE SHOWN IN THEIR APPROXIMATE LOCATIONS BASED UPON RECORD INFORMATION AVAILABLE TO THE ENGINEER AT THE TIME OF PREPARATION OF THESE PLANS. LOCATIONS MAY NOT HAVE BEEN VERIFIED IN THE FIELD AND NO GUARANTEE IS MADE. THE ELEVATIONS OF MANY EXISTING UTILITIES, INCLUDING UNDERGROUND GAS, ELECTRICAL, TELEPHONE/COMMUNICATIONS, AND WATER ARE UNKNOWN.
3. EXISTING PIPE SIZES AND MATERIAL WERE TAKEN FROM FIELD MARKINGS AND RECORD DRAWINGS. WHERE MATERIAL OF EXISTING UTILITY IS CRITICAL, CONTRACTOR SHALL VERIFY THE SIZE AND MATERIAL OF UTILITY. CONTRACTOR IS RESPONSIBLE FOR POTHOLES AND VERIFYING THE DEPTHS OF ANY EXISTING CRITICAL UTILITY CROSSINGS WITH THE PROPOSED SEWER CONSTRUCTION.
4. ALL EXCAVATION BACKFILL AND PAVEMENT SECTIONS WITHIN STREET RIGHT-OF-WAY SHALL BE DONE IN ACCORDANCE WITH THE REQUIREMENTS OF THE ENGINEER OF THE PUBLIC AGENCY HAVING JURISDICTION AND DISTRICT STANDARD SPECIFICATIONS AND DETAILS. IN CASE OF CONFLICT BETWEEN PUBLIC AGENCY AND DISTRICT, AGENCY'S REQUIREMENTS SHALL TAKE PRECEDENCE.
5. CONTRACTOR WILL OBTAIN ENCROACHMENT PERMITS FROM THE CITY OF CUPERTINO. CONTRACTOR SHALL OBTAIN AND PROVIDE NECESSARY BUSINESS AND CONTRACTOR LICENSES CERTIFICATE PER THE CITY'S REQUIREMENT. CONTRACTOR SHALL ADHERE TO CONSTRUCTION HOURS AND PROVIDE ADDITIONAL OR REVISED TRAFFIC CONTROL PLANS AS REQUESTED BY THE CITY. A COPY OF THE ENCROACHMENT PERMIT SHALL BE ON THE JOB DURING CONSTRUCTION.
6. FILL MATERIAL SHALL BE COMPACTED TO A MINIMUM OF TWO AND ONE HALF (2.5) FEET ABOVE THE TOP OF THE PIPE ELEVATION BY METHODS THAT WILL NOT DAMAGE THE PIPE OR TWO (2) SLURRY MIX. FILL MATERIAL MUST ATTAIN A MINIMUM OF NINETY FIVE (95) PERCENT RELATIVE COMPACTION IN PAVEMENT AREAS IN ACCORDANCE WITH THE STATE OF CALIFORNIA STANDARD SPECIFICATIONS.
7. THE DISTRICT ENGINEER SHALL BE NOTIFIED TWO (2) WORKING DAYS IN ADVANCE OF STARTING CONSTRUCTION. 20863 STEVENS CREEK BOULEVARD, SUITE 100, CUPERTINO, CA 95014 (408)253-7071.
8. MANHOLE CASTINGS SHALL BE ADJUSTED TO FINAL GRADE IN ACCORDANCE WITH THE STANDARD SPECIFICATIONS OF THE CUPERTINO SANITARY DISTRICT OR AS DIRECTED BY THE DISTRICT ENGINEER.
9. THE GENERAL CONTRACTOR SHALL BE RESPONSIBLE FOR THE PREVENTION OF CONSTRUCTION DEBRIS ENTERING THE EXISTING SANITARY SEWER SYSTEM DUE TO THE CONSTRUCTION ACTIVITIES ASSOCIATED WITH THIS PROJECT AND THE CONTRACTOR SHALL PAY ALL COSTS ASSOCIATED WITH THE RELEASE OF CONSTRUCTION DEBRIS INTO THE EXISTING SANITARY SEWER SYSTEM DUE TO THE CONSTRUCTION ACTIVITIES ASSOCIATED WITH THIS PROJECT.
10. GENERAL CONTRACTOR SHALL BE RESPONSIBLE FOR THE PREVENTION OF A SEWAGE SPILL ASSOCIATED WITH THE CONTRACTOR'S ACTIVITIES AND SHALL PAY ALL COSTS ASSOCIATED WITH THE RELEASE OF SEWAGE INTO SURFACE DRAINAGE SYSTEM AND DOWNSTREAM SURFACE WATERS.
11. ACCESS FOR PEDESTRIANS AND VEHICLES SHALL BE PROVIDED AT ALL TIMES UNLESS APPROVED IN WRITING BY THE DISTRICT ENGINEER.
12. SANITARY SEWER MANHOLES AND CLEANOUTS SHALL BE MARKED WITH "SANITARY" OR "SANITARY SEWER".
13. CONTRACTOR SHALL SUPPLY ALL EQUIPMENT, LABOR, AND MATERIALS NECESSARY TO PERFORM THE WORK SHOWN ON THE PLANS.
14. IT SHALL BE THE RESPONSIBILITY OF THE CONTRACTORS TO COORDINATE THEIR WORK SO AS TO ELIMINATE CONFLICTS AND WORK TOWARD THE GENERAL GOOD AND COMPLETION OF THE ENTIRE PROJECT.
15. ALL WORKMANSHIP AND MATERIALS FURNISHED BY THE CONTRACTOR SHALL BE THE KIND AND QUALITY DESCRIBED IN THE SPECIFICATIONS AND SHALL BE FIRST CLASS THROUGHOUT. NEITHER FINAL ACCEPTANCE NOR FINAL PAYMENT BY THE DISTRICT SHALL RELIEVE THE CONTRACTOR OF RESPONSIBILITY FOR FAULTY MATERIALS OR WORKMANSHIP.
16. IN THE EVENT OF ANY CONFLICT OF INFORMATION SHOWN ON THESE PLANS OR ANY CONFLICT BETWEEN THESE PLANS AND THE INTENT OF A CONSISTENT AND FUNCTIONAL PRODUCT, THE CONTRACTOR SHALL NOTIFY THE DISTRICT IN WRITING, UPON WHICH NOTICE THE DISTRICT SHALL RESOLVE THE CONFLICTS BY THE ISSUANCE OF A WRITTEN ORDER, REVISED PLANS OR BOTH. THE CONTRACTOR SHALL BEAR FULL COST AND RESPONSIBILITY FOR WORK AFFECTED BY SUCH CONFLICTS AND PERFORMED BY CONTRACTOR PRIOR TO SUCH NOTICE TO THE DISTRICT AND ISSUANCE OF SUCH ORDER AND/OR REVISED PLANS.

LEGEND

DISPLAY	DESCRIPTION
---s---	EXISTING SANITARY SEWER MAIN
---S---	PROPOSED SANITARY SEWER MAIN
⊙	SANITARY SEWER MANHOLE
---sd---	EXISTING STORM DRAIN
---w---	EXISTING WATER
---g---	EXISTING NATURAL GAS
---e---	EXISTING ELECTRICAL
---E---	PROPOSED ELECTRICAL
---+---(oh)---	EXISTING OVERHEAD
---	STREET CENTERLINE
---	EXISTING RIGHT OF WAY
---	EXISTING EASEMENT
---	STREET ALIGNMENT
///s///	ABANDON EXISTING UTILITY
XsX	REMOVE EXISTING UTILITY

ABBREVIATIONS:

CHP	CALIFORNIA HIGHWAY PATROL
ICO	IRRIGATION CROSSOVER
CR	CURB RAMP
CSD	CUPERTINO SANITARY DISTRICT

17. CONTRACTOR SHALL PROVIDE ADEQUATE DUST CONTROL AT ALL TIMES AS REQUIRED BY THE DISTRICT. NO VISIBLE AIRBORNE PARTICLES WILL BE ALLOWED AT ANY TIME DURING CONSTRUCTION.
18. CONTRACTOR SHALL EXERCISE ALL NECESSARY CAUTION TO AVOID DAMAGE TO ANY EXISTING TREES, OR SURFACE IMPROVEMENTS OR TO ANY EXISTING DRAINAGE STRUCTURE, WATER STRUCTURE, SEWER CLEANOUTS, MANHOLES, OR JUNCTION BOXES FOR UNDERGROUND ELECTRIC, GAS, TELEPHONE, CABLE TV, STORM, SANITARY, WATER, OR OTHER UTILITIES WHICH ARE TO REMAIN IN PLACE AND SHALL BEAR FULL COST AND RESPONSIBILITY FOR ANY DAMAGE THERETO.
19. ALL CONTRACTORS SHALL CONTACT BOTH UNDERGROUND SERVICE ALERT USA 811 AND THE AFFECTED UTILITY COMPANIES PRIOR TO STARTING WORK TO REQUEST AND OBTAIN THE MARKING OF EXISTING UNDERGROUND UTILITIES. EXCAVATION FOR UNDERGROUND FACILITIES SHALL NOT BE PERMITTED PRIOR TO CONTACTING UNDERGROUND SERVICE ALERT AND VERIFICATION OF ALL OTHER EXISTING UTILITY LOCATIONS NOT INCLUDED IN USA LOCATION SERVICES.
20. IN CONFORMANCE WITH GENERALLY ACCEPTED CONSTRUCTION PRACTICES, THE CONTRACTOR SHALL ASSUME SOLE AND COMPLETE RESPONSIBILITY FOR THE JOBSITE CONDITIONS DURING THE COURSE OF CONSTRUCTION OF THE PROJECT, INCLUDING SAFETY OF ALL PERSONS AND PROPERTY. THIS REQUIREMENT SHALL APPLY CONTINUOUSLY AND SHALL NOT BE LIMITED TO NORMAL WORKING HOURS.
21. CONTRACTOR SHALL PROTECT AND PRESERVE ALL EXISTING FACILITIES DURING THE COURSE OF CONSTRUCTION. THIS INCLUDES EXISTING SIDEWALK, CURB, STORM CATCH BASIN, STORM DRAIN PIPE, TRAFFIC SIGNAL BOX, AND STRUCTURES ON ADJACENT PRIVATE PROPERTY. CONTRACTOR SHALL IMMEDIATELY REPORT ANY DAMAGE TO THE EXISTING FACILITIES TO THE DISTRICT INSPECTOR AND APPROPRIATE MEASURES WILL BE TAKEN TO REPAIR OR REPLACE THE DAMAGED ITEM.
22. CONTRACTOR SHALL PERFORM WORK WITH THE LEAST AMOUNT OF DISRUPTION TO THE RESIDENTS.
23. ASPHALT TO CONFORM TO SECTION 39 "HOT MIX ASPHALT" OF STATE STANDARD SPECIFICATIONS; TYPE A WITH 1/2" MAXIMUM, MEDIUM GRADATION, UNLESS OTHERWISE NOTED.
24. PORTLAND CEMENT CONCRETE SHALL CONFORM TO CLASS A, WITH A MINIMUM 28 DAY COMPRESSIVE STRENGTH OF 3000 PSI.
25. THE CONTRACTOR SHALL NOT ORDER OR PLACE ANY PORTLAND CEMENT CONCRETE OR ASPHALT CONCRETE PAVING UNTIL THE FORMS AND SUBGRADE AND/OR AGGREGATE BASE HAVE BEEN INSPECTED BY THE DISTRICT INSPECTOR AS APPROVED BY THE ENGINEER IN CHARGE OF CONSTRUCTION.
26. EDGE OF EXISTING PAVEMENT SHALL BE TACK COATED PRIOR TO CONSTRUCTION OF NEW PAVEMENT.
27. ALL EXISTING FACILITIES SHALL BE ADJUSTED TO FINISHED GRADE AS DIRECTED BY THE DISTRICT INSPECTOR. MANHOLES, WATER VALVE BOXES, CLEAN OUT FRAMES AND COVERS SHALL BE BROUGHT TO FINISHED GRADE BY THE CONTRACTOR AFTER PAVING IS COMPLETED.
28. MATERIALS FOR PIPE, MANHOLES AND CLEANOUTS AND INSTALLATION PROCEDURES SHALL BE IN ACCORDANCE WITH APPLICABLE SECTIONS OF THE DISTRICT'S STANDARD SPECIFICATIONS AND THESE PLANS AND DETAILS SHOWN HEREIN.
29. ALL TRENCH EXCAVATION AND BACKFILL FOR SEWER LINES SHALL CONFORM TO THE REQUIREMENTS OF LOCAL JURISDICTION'S STANDARD SPECIFICATIONS. JETTING OF BACKFILL MATERIALS TO ACHIEVE COMPACTION IS NOT ALLOWED.
30. ALL TRENCHES AND SHAFTS SHALL BE CONSTRUCTED IN STRICT COMPLIANCE WITH THE APPLICABLE SECTIONS OF CALIFORNIA AND FEDERAL O.S.H.A. REQUIREMENTS AND OTHER APPLICABLE SAFETY ORDINANCES. CONTRACTOR SHALL BEAR FULL RESPONSIBILITY FOR SELECTION OF SHAFT SIZES AND LOCATIONS TO ACCOMMODATE PLANNED MEANS AND METHODS.



20863 STEVENS CREEK BLVD, STE 100
CUPERTINO, CA 95014
(408) 255-2137

DESIGNED BY :	ED			
DRAWN BY :	ED			
CHECKED BY :	BP			
DATE :	9/03/2019			
SCALE :		No.	DESCRIPTION	DATE
MTCo JOB No. :	CU-19104		REVISIONS	



CUPERTINO SANITARY DISTRICT
20863 STEVENS CREEK BOULEVARD, SUITE 100
CUPERTINO, CA 95014
(408) 255-2137 FAX (408) 253-5173

REGISTERED CIVIL ENGINEER _____ DATE _____

CUSD SIGNIFICANT DEFECT REPAIR PROJECT
GENERAL NOTES

WORK ORDER No. _____ ADVERTISEMENT DATE: _____ CONTRACT No. _____

SHEET

2

OF 9 SHEETS

G-1

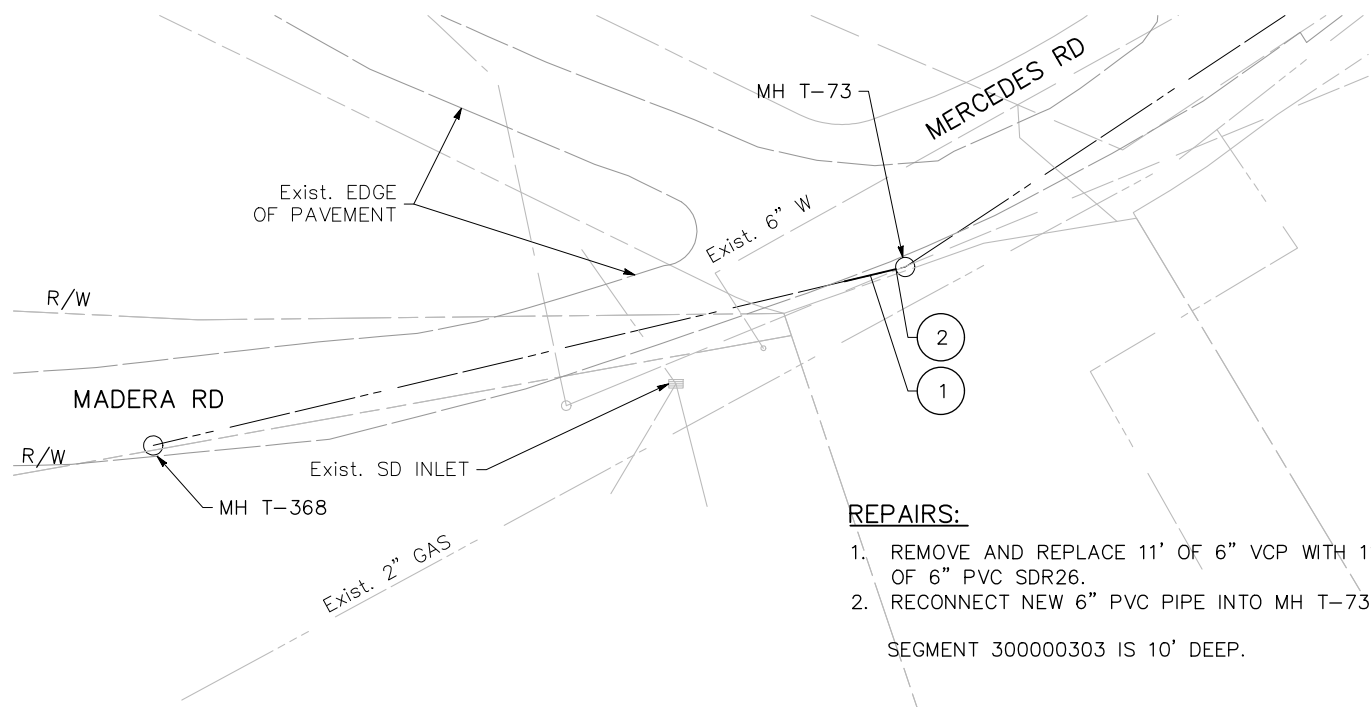

SEGMENT 30000303
 LOCATION 1 – MERCEDES ROAD
 1"=20'

- REPAIRS:**
1. REMOVE AND REPLACE 11' OF 6" VCP WITH 11' OF 6" PVC SDR26.
 2. RECONNECT NEW 6" PVC PIPE INTO MH T-73
- SEGMENT 30000303 IS 10' DEEP.

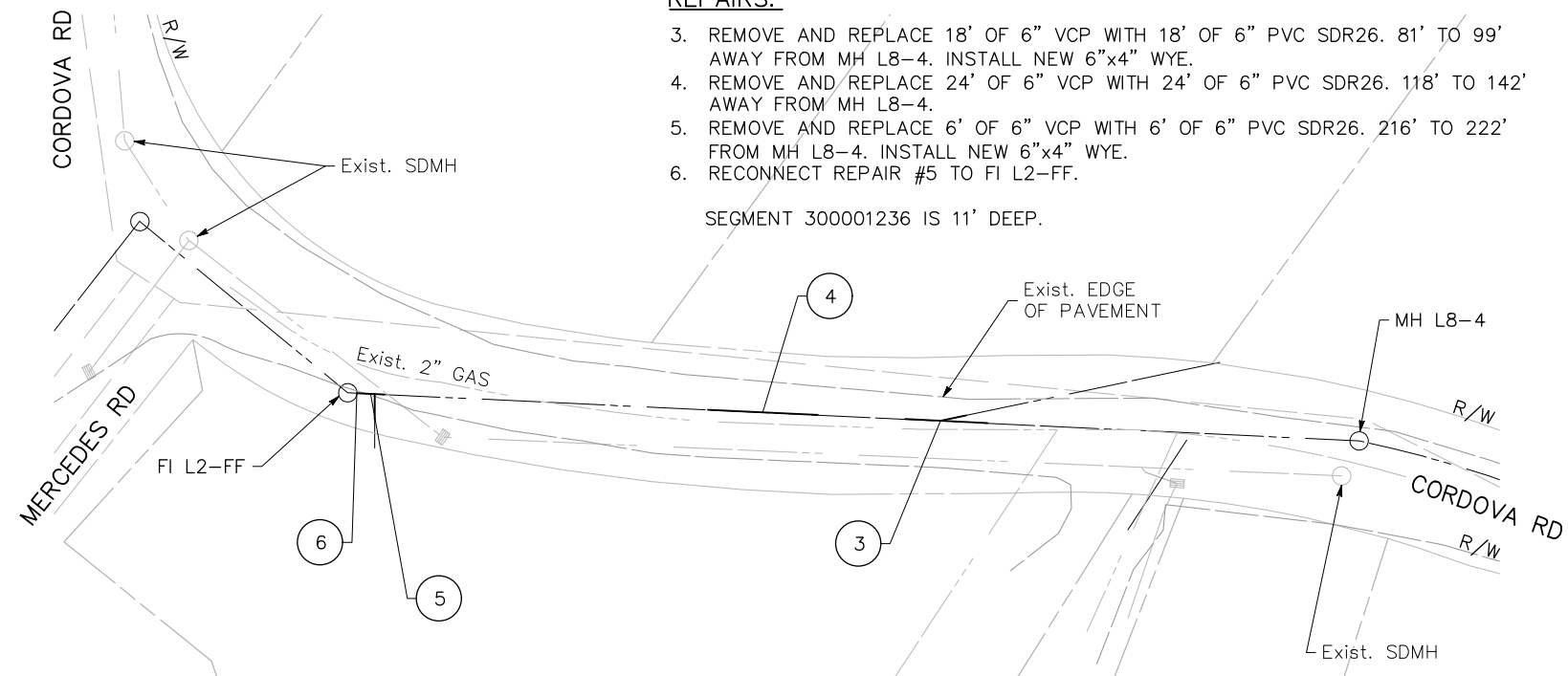

SEGMENT 300001236
 LOCATION 2 – CORDOVA ROAD
 1"=20'

- REPAIRS:**
3. REMOVE AND REPLACE 18' OF 6" VCP WITH 18' OF 6" PVC SDR26. 81' TO 99' AWAY FROM MH L8-4. INSTALL NEW 6"x4" WYE.
 4. REMOVE AND REPLACE 24' OF 6" VCP WITH 24' OF 6" PVC SDR26. 118' TO 142' AWAY FROM MH L8-4.
 5. REMOVE AND REPLACE 6' OF 6" VCP WITH 6' OF 6" PVC SDR26. 216' TO 222' FROM MH L8-4. INSTALL NEW 6"x4" WYE.
 6. RECONNECT REPAIR #5 TO FI L2-FF.
- SEGMENT 300001236 IS 11' DEEP.

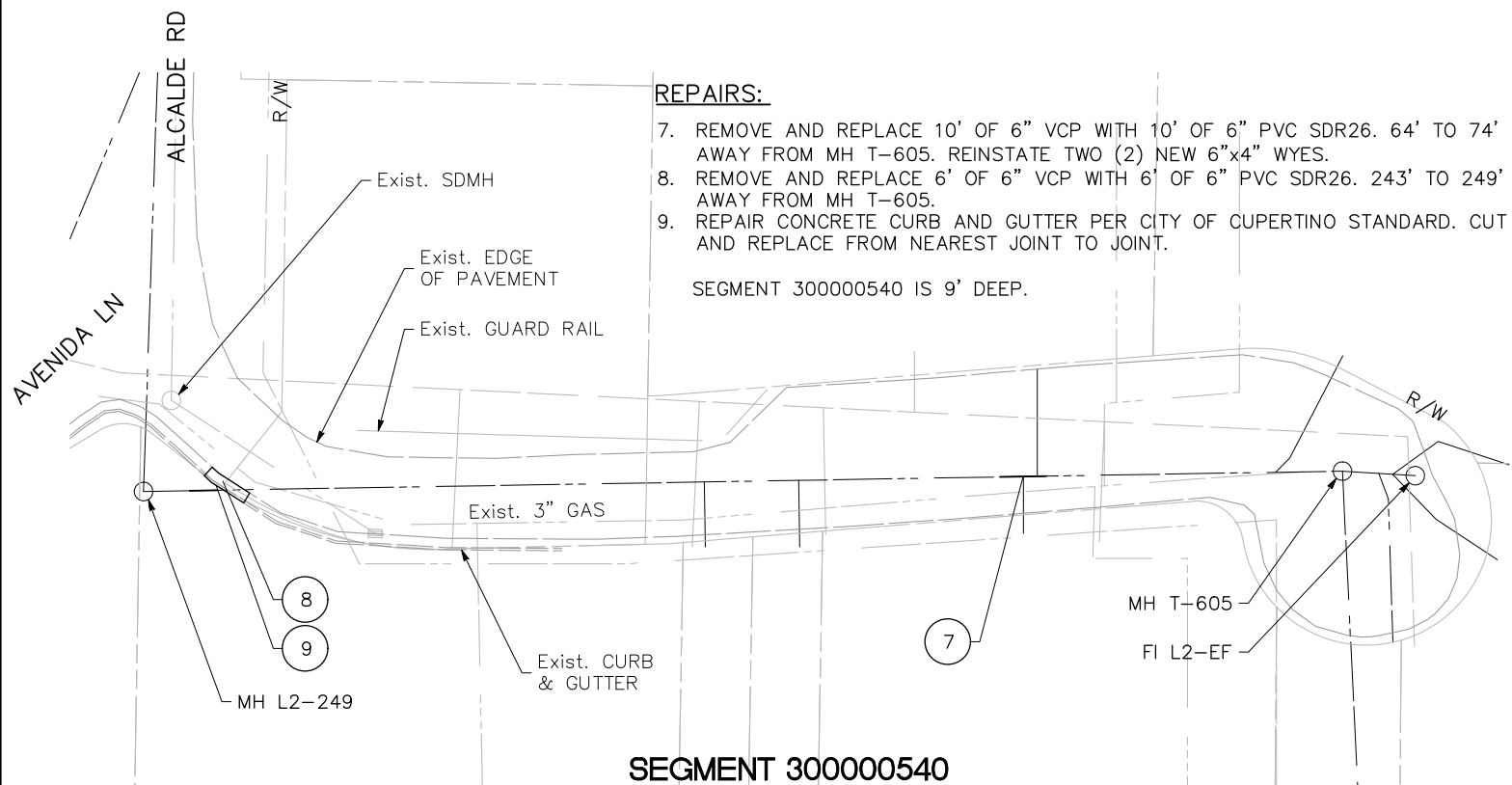

SEGMENT 30000540
 LOCATION 3 – SAN FELIPE ROAD
 1"=20'

- REPAIRS:**
7. REMOVE AND REPLACE 10' OF 6" VCP WITH 10' OF 6" PVC SDR26. 64' TO 74' AWAY FROM MH T-605. REINSTATE TWO (2) NEW 6"x4" WYES.
 8. REMOVE AND REPLACE 6' OF 6" VCP WITH 6' OF 6" PVC SDR26. 243' TO 249' AWAY FROM MH T-605.
 9. REPAIR CONCRETE CURB AND GUTTER PER CITY OF CUPERTINO STANDARD. CUT AND REPLACE FROM NEAREST JOINT TO JOINT.
- SEGMENT 30000540 IS 9' DEEP.

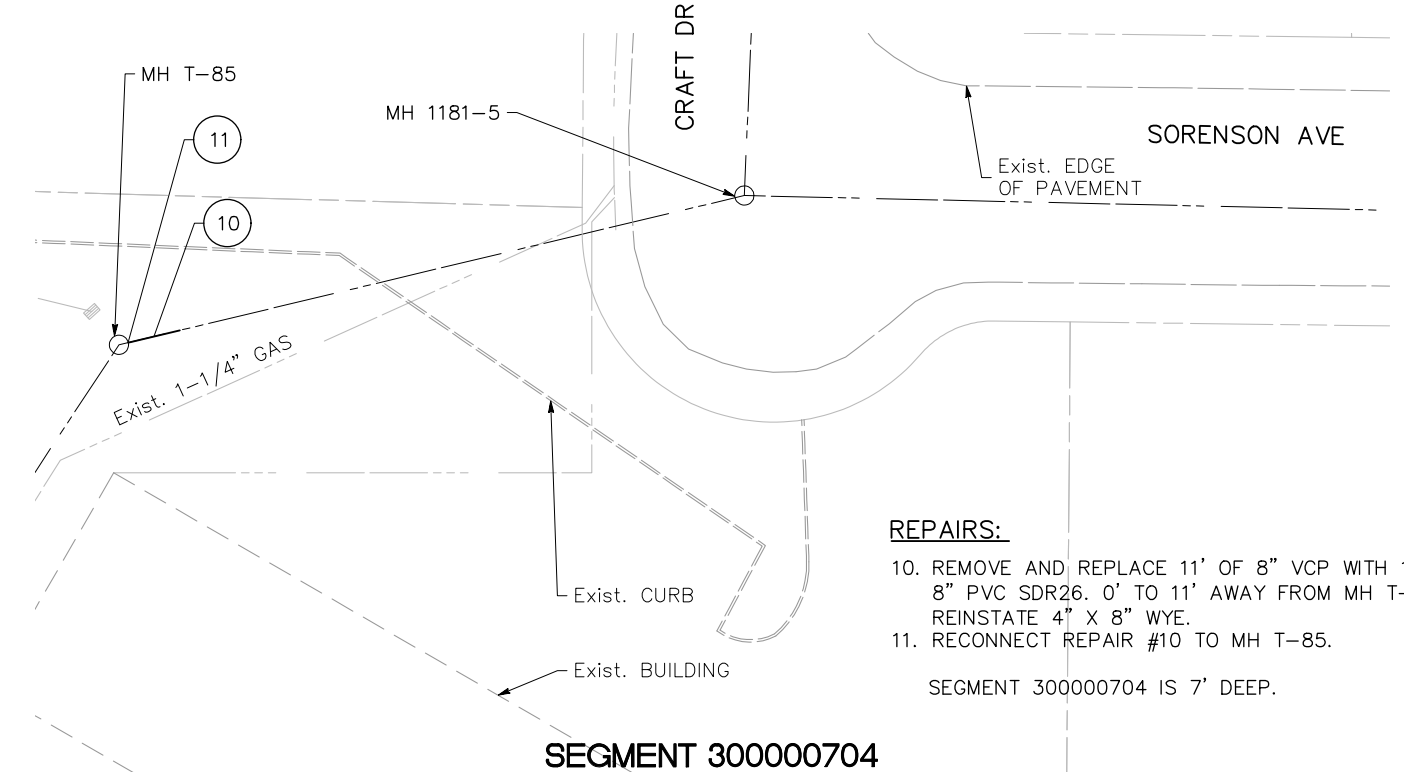

SEGMENT 30000704
 LOCATION 4 – FOUNTAINBLEU APARTMENTS EASEMENT
 1"=20'

- REPAIRS:**
10. REMOVE AND REPLACE 11' OF 8" VCP WITH 11' OF 8" PVC SDR26. 0' TO 11' AWAY FROM MH T-85. REINSTATE 4" X 8" WYE.
 11. RECONNECT REPAIR #10 TO MH T-85.
- SEGMENT 30000704 IS 7' DEEP.

65% SUBMITTAL

MARK THOMAS
 20863 STEVENS CREEK BLVD, STE 100
 CUPERTINO, CA 95014
 (408) 255-2137

DESIGNED BY :	ED				
DRAWN BY :	ED				
CHECKED BY :	IT				
DATE :	9/30/2022				
SCALE :	#####	No.	DESCRIPTION	DATE	BY
MTCo JOB No. :	CU-13101		REVISIONS		

CUPERTINO SANITARY DISTRICT
 20863 STEVENS CREEK BOULEVARD, SUITE 100
 CUPERTINO, CA 95014
 (408) 253-7071 FAX (408) 253-5173

REGISTERED CIVIL ENGINEER _____ DATE _____

CUSD SIGNIFICANT DEFECT REPAIR PROJECT LAYOUT SHEET

WORK ORDER No. _____ ADVERTISEMENT DATE: _____ CONTRACT No. _____

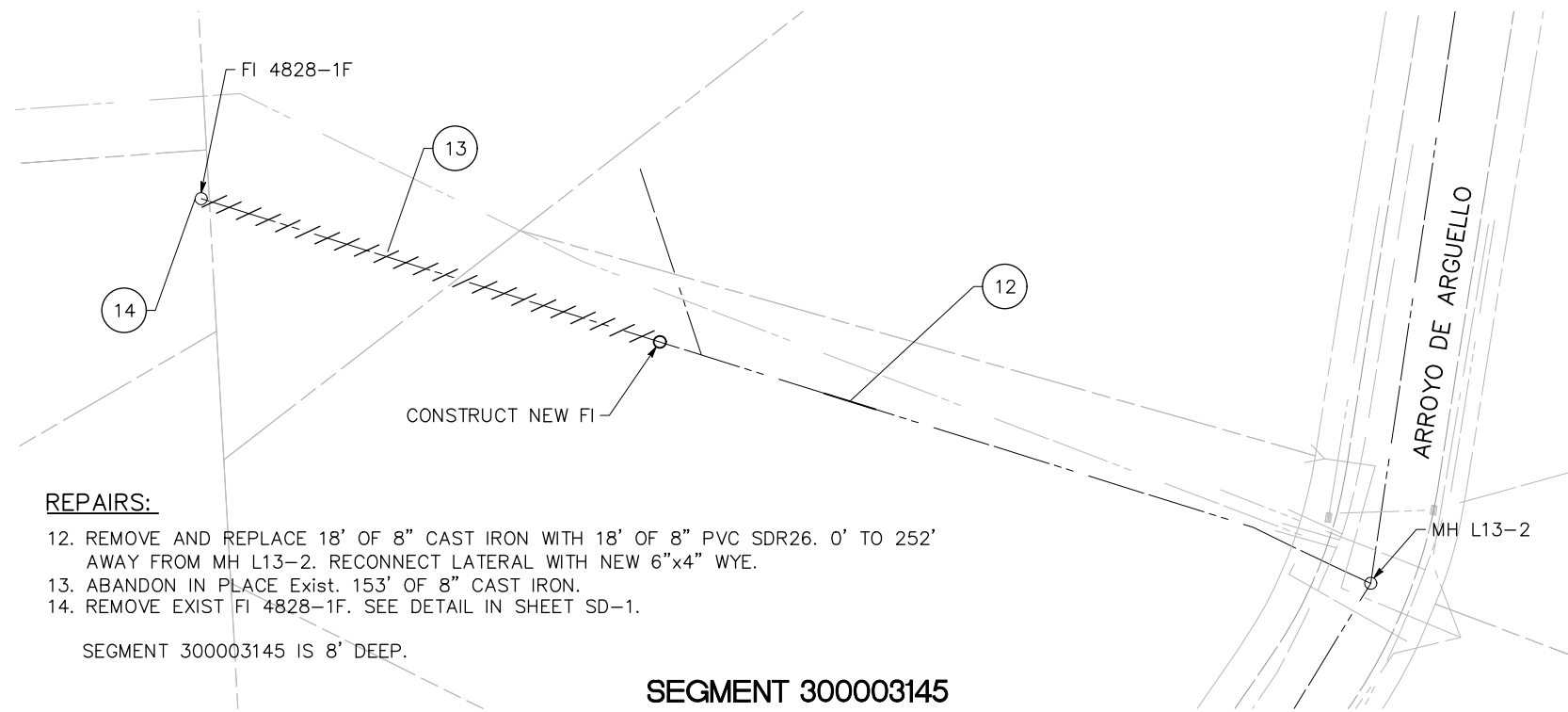

REPAIRS:

- 12. REMOVE AND REPLACE 18' OF 8" CAST IRON WITH 18' OF 8" PVC SDR26. 0' TO 252' AWAY FROM MH L13-2. RECONNECT LATERAL WITH NEW 6"x4" WYE.
- 13. ABANDON IN PLACE Exist. 153' OF 8" CAST IRON.
- 14. REMOVE EXIST FI 4828-1F. SEE DETAIL IN SHEET SD-1.

SEGMENT 300003145 IS 8' DEEP.

SEGMENT 300003145
 LOCATION 8 - ARROYO DE ARGUELLO EASEMENT
 1"=30'

65% SUBMITTAL

MARK THOMAS
 20863 STEVENS CREEK BLVD, STE 100
 CUPERTINO, CA 95014
 (408) 255-2137

DESIGNED BY :	ED			
DRAWN BY :	ED			
CHECKED BY :	IT			
DATE :	9/30/2022			
SCALE :	#####	No.	DESCRIPTION	DATE BY
MTCo JOB No. :	CU-13101	REVISIONS		

CUPERTINO SANITARY DISTRICT
 ESTABLISHED 1966

CUPERTINO SANITARY DISTRICT
 20863 STEVENS CREEK BOULEVARD, SUITE 100
 CUPERTINO, CA 95014
 (408) 253-7071 FAX (408) 253-5173

REGISTERED CIVIL ENGINEER _____ DATE _____

CUSD SIGNIFICANT DEFECT REPAIR PROJECT LAYOUT SHEET

WORK ORDER No.	ADVERTISEMENT DATE:	CONTRACT No.
----------------	---------------------	--------------

SHEET 4 OF 9 SHEETS
 L-2

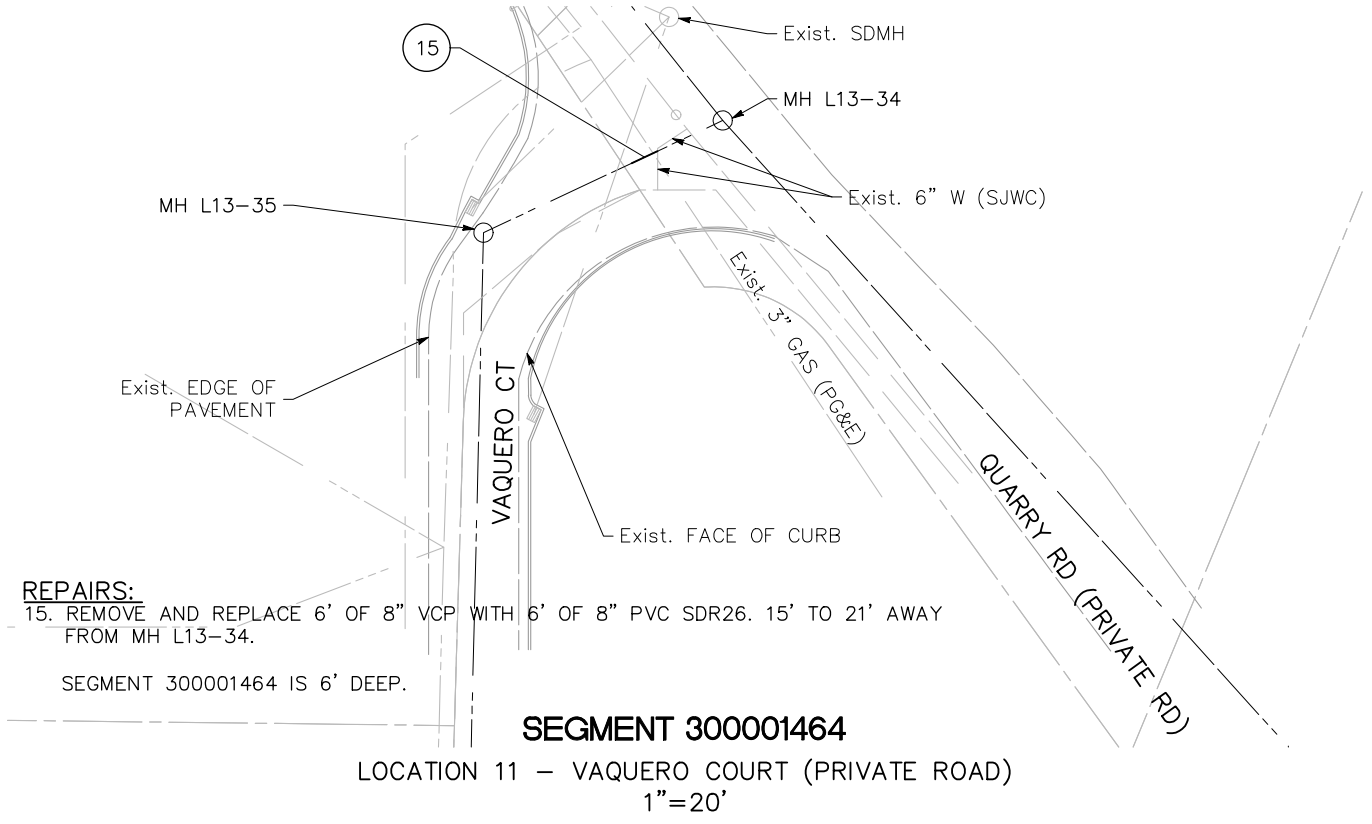

REPAIRS:
 15. REMOVE AND REPLACE 6' OF 8" VCP WITH 6' OF 8" PVC SDR26. 15' TO 21' AWAY FROM MH L13-34.
 SEGMENT 300001464 IS 6' DEEP.

SEGMENT 300001464
 LOCATION 11 - VAQUERO COURT (PRIVATE ROAD)
 1"=20'

REPAIRS:
 16. REMOVE AND REPLACE 16' OF 6" PVC WITH 16' OF 6" PVC SDR26. 72' TO 88' AWAY FROM MH T-716
 SEGMENT 300000669 IS 6' DEEP.

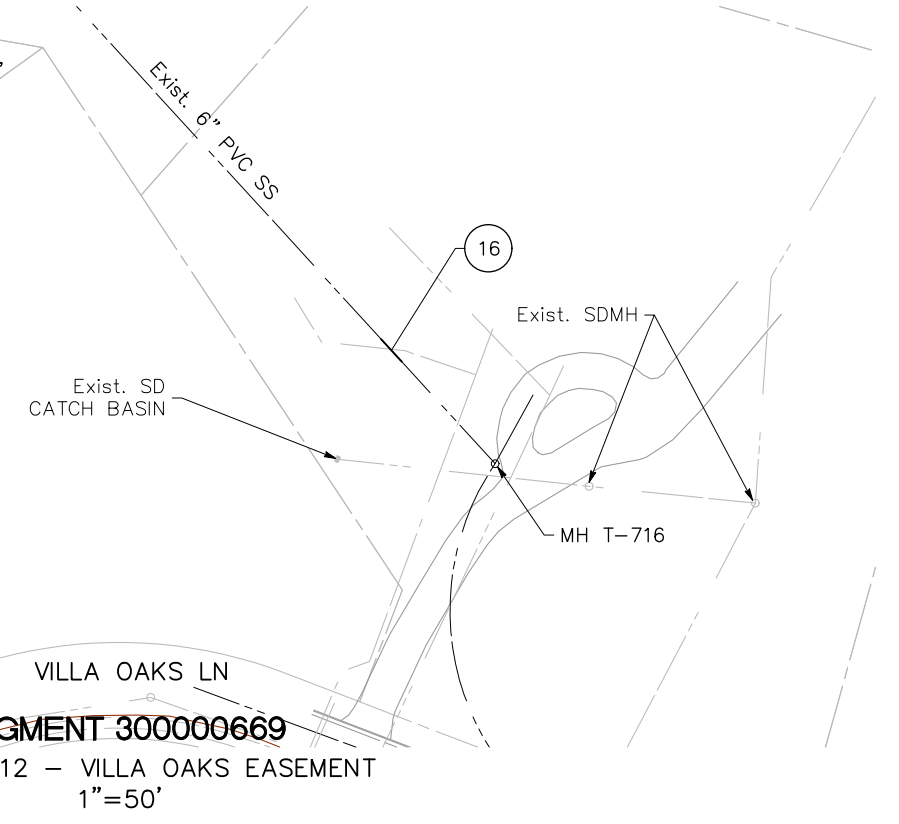

SEGMENT 300000669
 LOCATION 12 - VILLA OAKS EASEMENT
 1"=50'

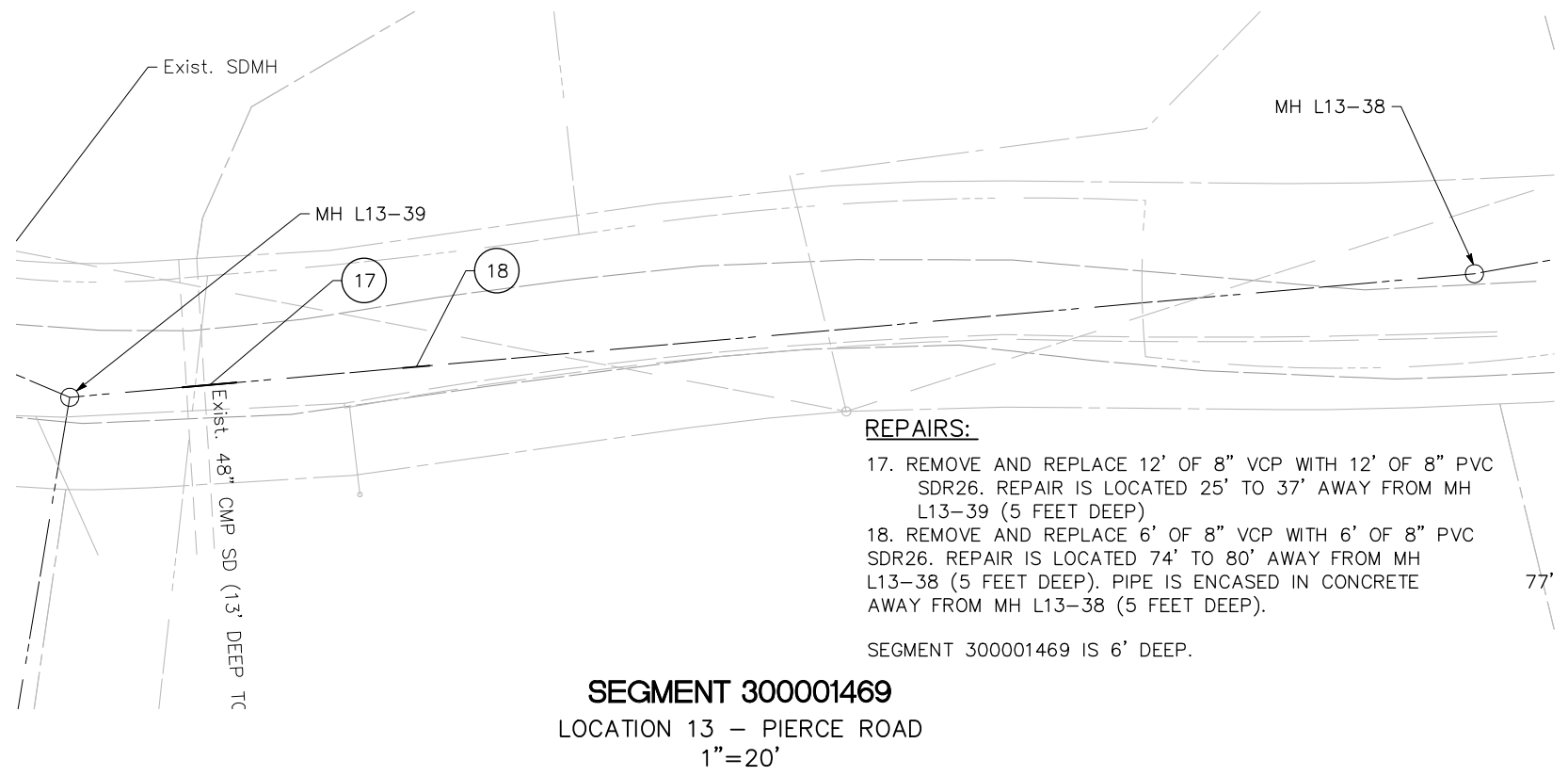

REPAIRS:
 17. REMOVE AND REPLACE 12' OF 8" VCP WITH 12' OF 8" PVC SDR26. REPAIR IS LOCATED 25' TO 37' AWAY FROM MH L13-39 (5 FEET DEEP)
 18. REMOVE AND REPLACE 6' OF 8" VCP WITH 6' OF 8" PVC SDR26. REPAIR IS LOCATED 74' TO 80' AWAY FROM MH L13-38 (5 FEET DEEP). PIPE IS ENCASED IN CONCRETE AWAY FROM MH L13-38 (5 FEET DEEP).
 SEGMENT 300001469 IS 6' DEEP.

SEGMENT 300001469
 LOCATION 13 - PIERCE ROAD
 1"=20'

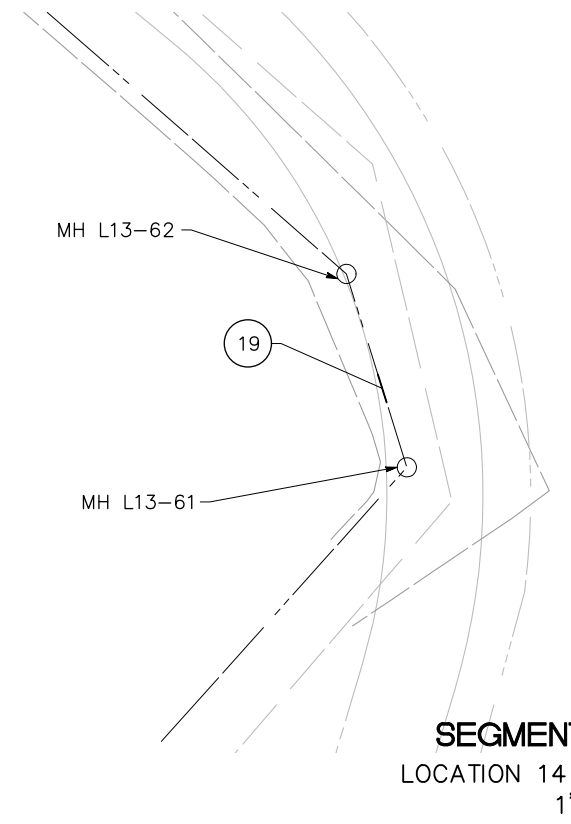

REPAIRS:
 19. REMOVE AND REPLACE 6' OF 8" VCP WITH 6' OF 8" PVC SDR26. 36' TO 42' AWAY FROM MH L13-62
 SEGMENT 300001496 IS 6' DEEP.

SEGMENT 300001496
 LOCATION 14 - VISTA REGINA
 1"=20'

65% SUBMITTAL

MARK THOMAS
 20863 STEVENS CREEK BLVD, STE 100
 CUPERTINO, CA 95014
 (408) 255-2137

DESIGNED BY :	ED				
DRAWN BY :	ED				
CHECKED BY :	IT				
DATE :	9/30/2022				
SCALE :	#####	No.	DESCRIPTION	DATE	BY
MTCs JOB No. :	CU-13101	REVISIONS			

CUPERTINO SANITARY DISTRICT
 20863 STEVENS CREEK BOULEVARD, SUITE 100
 CUPERTINO, CA 95014
 (408) 253-7071 FAX (408) 253-5173

REGISTERED CIVIL ENGINEER _____ DATE _____

CUSD SIGNIFICANT DEFECT REPAIR PROJECT LAYOUT SHEET

WORK ORDER No. _____ ADVERTISEMENT DATE: _____ CONTRACT No. _____

SHEET 5 OF 9 SHEETS
 L-3

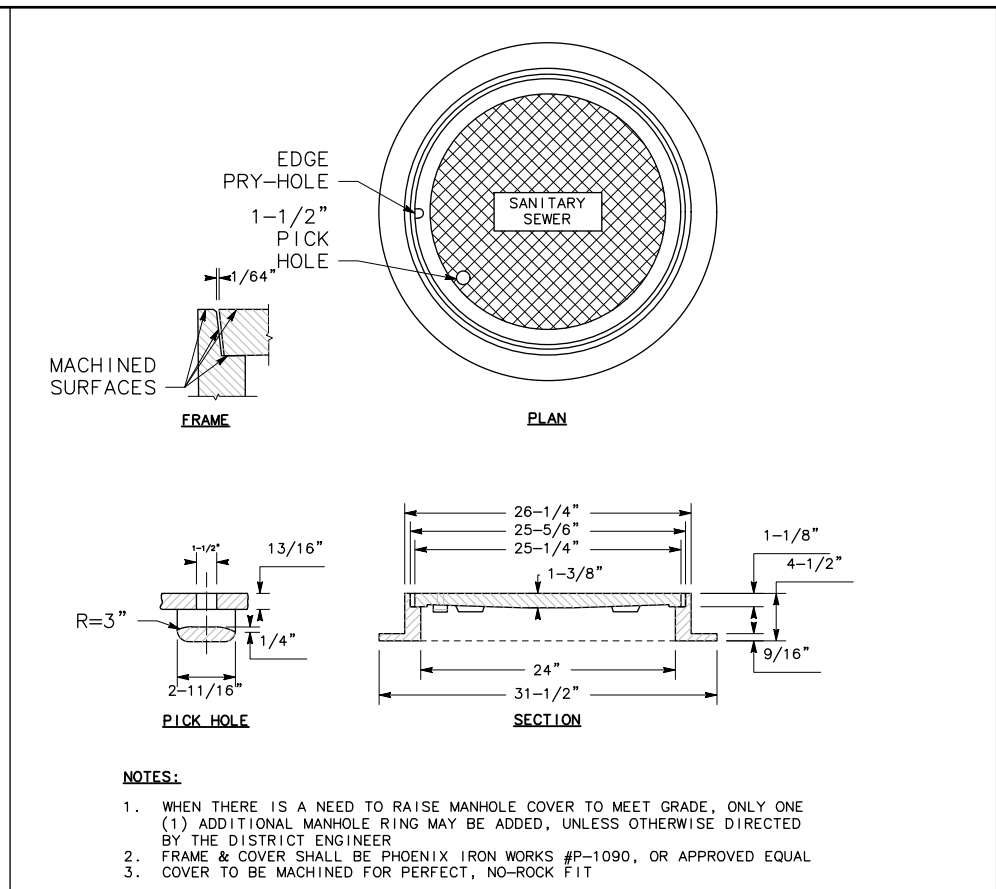
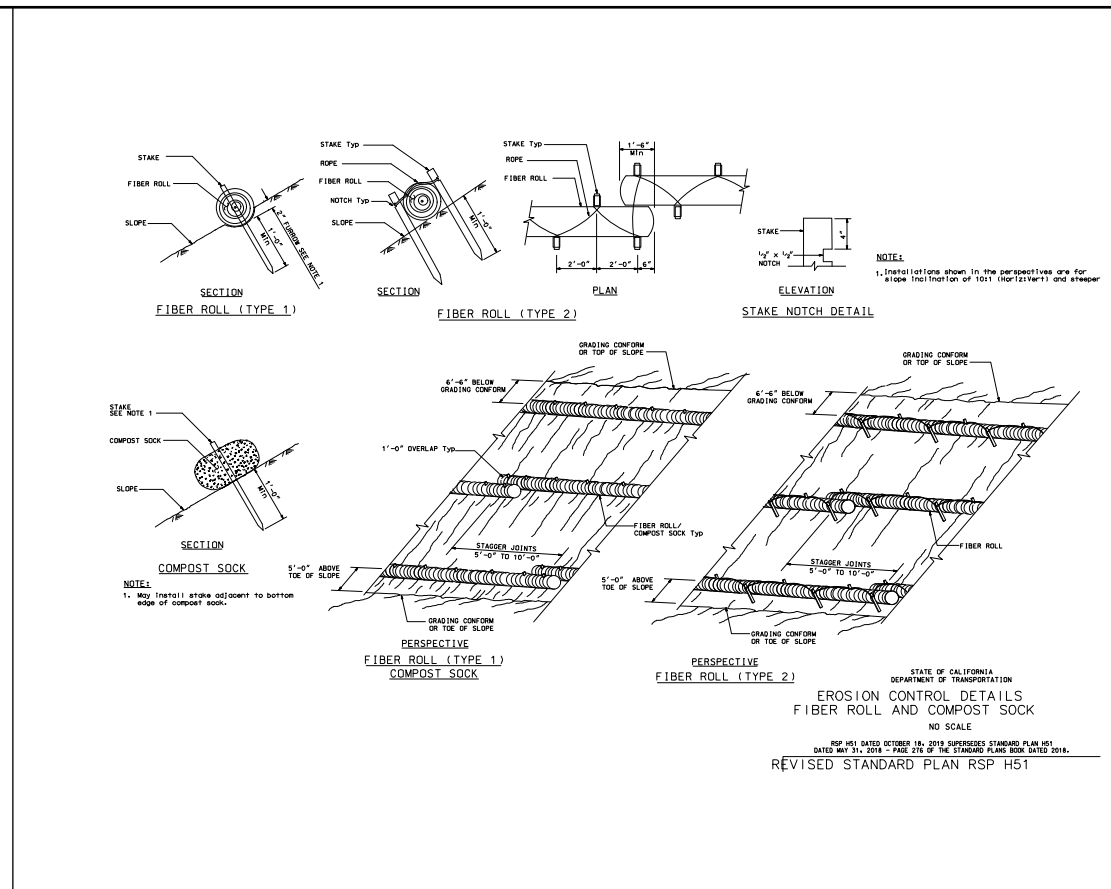
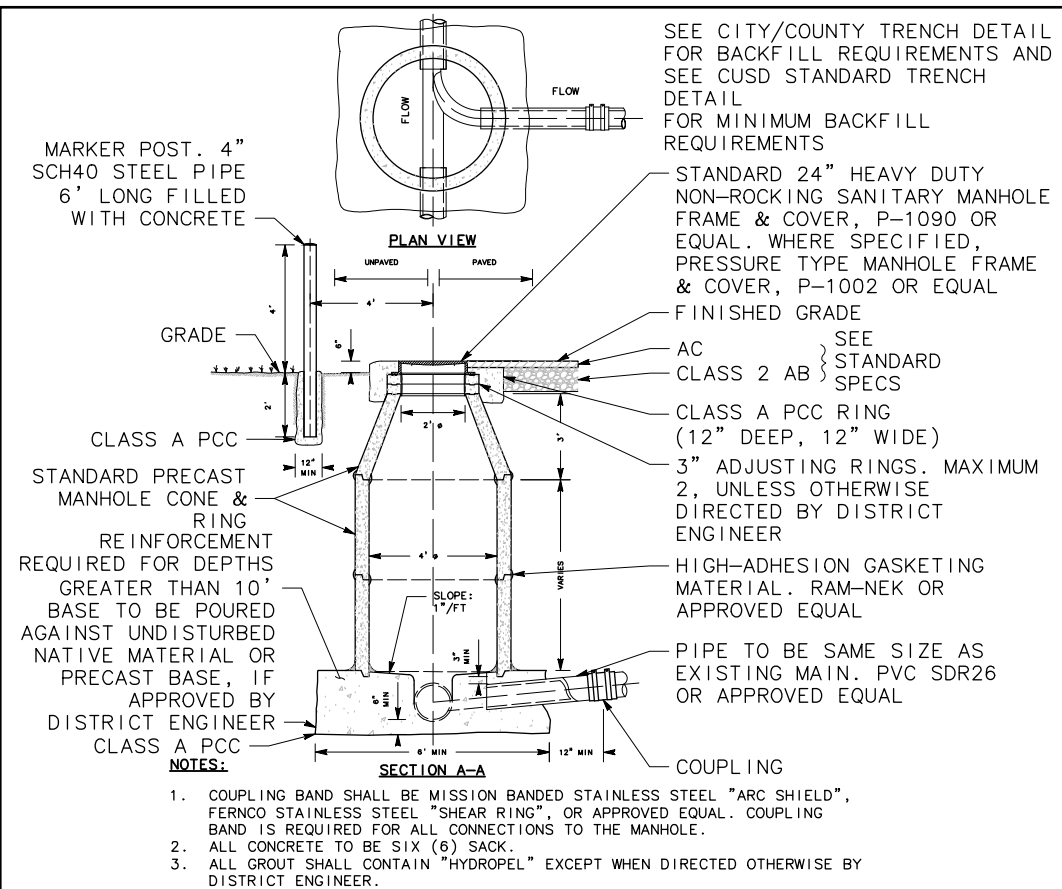

A 4' DIAMETER MANHOLE

B WATER POLLUTION CONTROL - FIBER ROLL

C MANHOLE FRAME & COVER

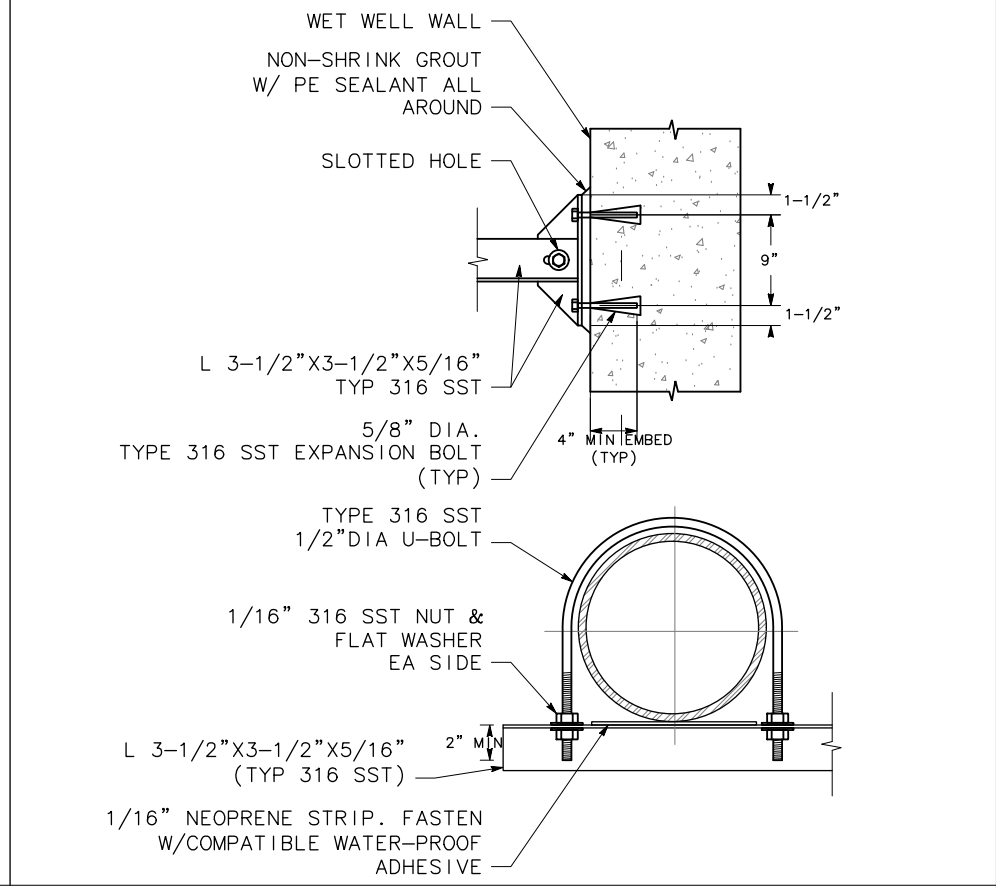
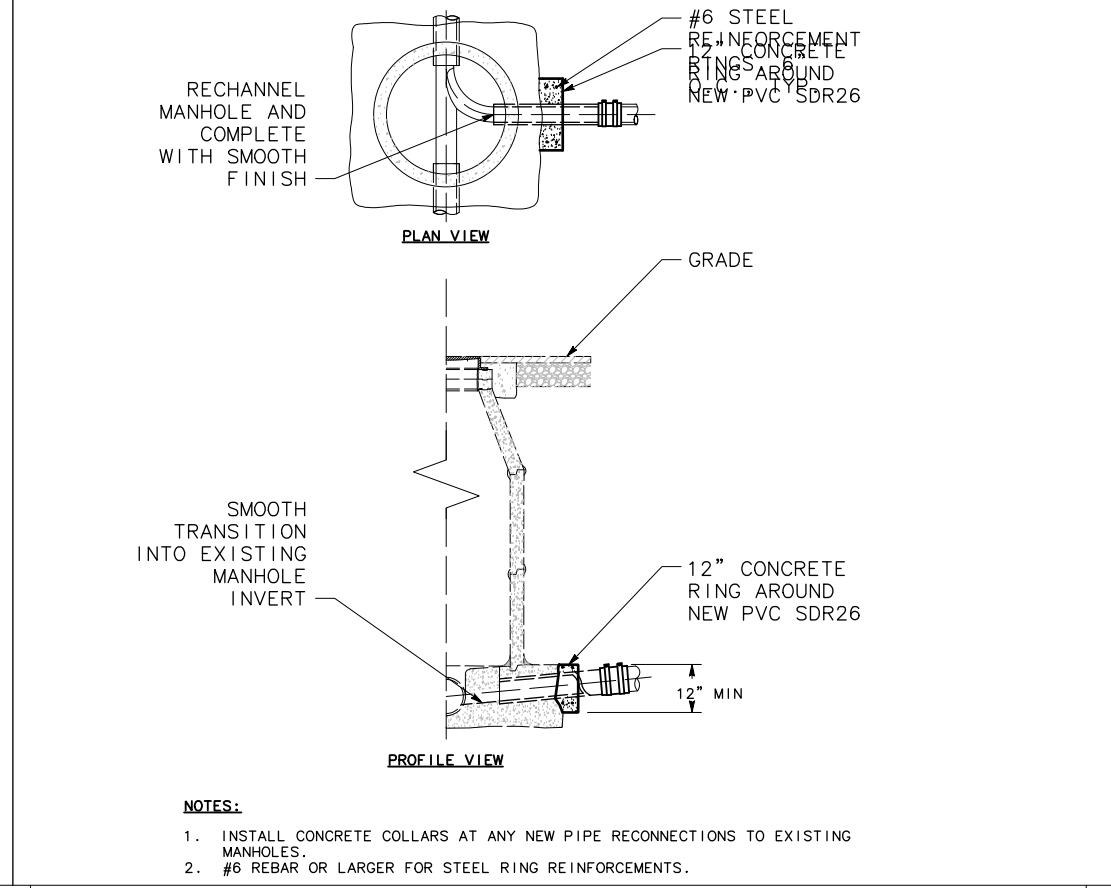
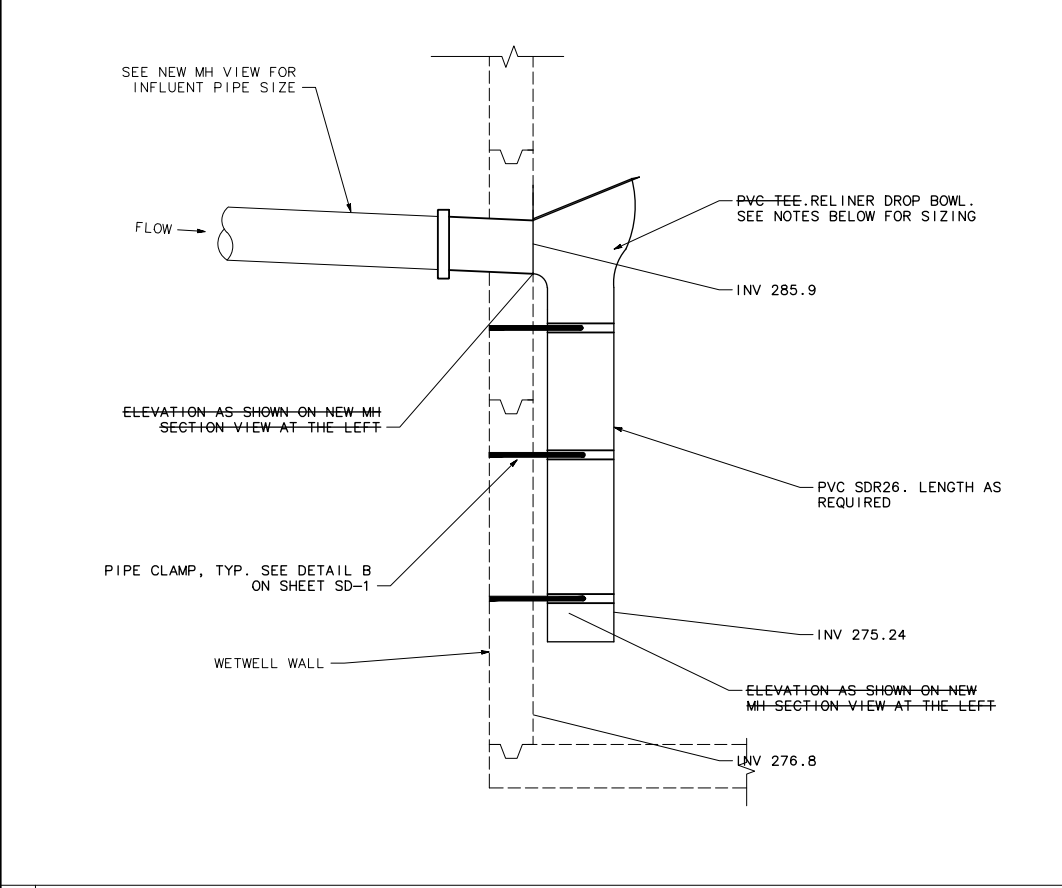

D INSIDE DROP MANHOLE

E CONNECTION AT MAHOLE

F PIPE CLAMP

MARK THOMAS

20863 STEVENS CREEK BLVD, STE 100
CUPERTINO, CA 95014
(408) 255-2137

DESIGNED BY :	ED			
DRAWN BY :	JB			
CHECKED BY :	BP			
DATE :	9/8/2022			
SCALE :		No.	DESCRIPTION	DATE BY
MTCO JOB No. :	CU-19104		REVISIONS	

CUPERTINO SANITARY DISTRICT

20863 STEVENS CREEK BOULEVARD, SUITE 100
CUPERTINO, CA 95014
(408) 255-2137 FAX (408) 253-5173

REGISTERED CIVIL ENGINEER _____ DATE _____

CUSD SIGNIFICANT DEFECT REPAIR PROJECT STANDARD DETAILS

WORK ORDER No. _____ ADVERTISEMENT DATE: _____ CONTRACT No. _____

SHEET 6 OF 9 SHEETS
SD-1

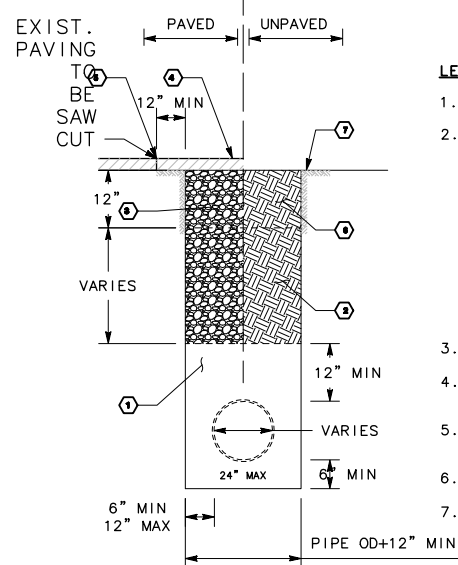

LEGEND:

1. BEDDING MATERIAL PER DISTRICT STANDARD SPECIFICATIONS
2. IN UNPAVED AREA, USE NATIVE BACKFILL COMPACTED TO 90% MINIMUM. IN PAVED AREA, USE CLASS 2 AGGREGATE BASE (3/4" MAXIMUM GRADATION) COMPACTED TO 95% MINIMUM. IF REQUIRED BY LOCAL AGENCY OR DISTRICT ENGINEER, USE 2 SACK SLURRY MIX CONCRETE BACKFILL. NATIVE MATERIAL MAY BE USED WITH DESIGNER OF RECORD RECOMMENDATION AND IF APPROVED BY THE DISTRICT ENGINEER.
3. CLASS 2 AGGREGATE BASE, 3/4" MAX.
4. 4" ASPHALT CONCRETE OR MATCH EXISTING DEPTH WHICHEVER IS GREATER.
5. APPLY TACK COAT ON SAW CUT EDGES PER SECTION 94 OF STATE SPECIFICATIONS.
6. TOPSOIL - MATCH EXISTING MINIMUM 90% RC(NATIVE MATERIAL)
7. GROUND COVER - MATCH EXISTING

NOTES:

1. RELATIVE COMPACTION (RC) SHALL MEAN COMPACTION IS DETERMINED BY CALIFORNIA COMPACTION TEST METHOD OR BY ASTM METHODS.
2. ASPHALT CONCRETE TO BE HMA (TYPE A) 1/2" MAX AGGREGATE PER SECTION 39 OF STATE STANDARD SPECIFICATIONS.
3. ALL BACKFILL SHALL BE PLACED AND COMPACTED IN 6" MAXIMUM LIFTS.
4. CLASS 2 AGGREGATE BASE PER SECTION 26 AND ASPHALT CONCRETE (HMA) PER SECTION 39 OF THE STATE STANDARD SPECIFICATIONS AND DISTRICT STANDARD SPECIFICATIONS.
5. EXISTING AC PAVEMENT SHALL BE REPLACED TO THE EDGE OF PAVEMENT WHEN THE EDGE OF THE TRENCH IS 2' OR LESS FROM THE EDGE OF PAVEMENT.
6. WIDTH OF THE OPEN TRENCH WHEN INSTALLING THE MAIN LINE SHALL TYPICALLY BE TWICE THE DIA OF THE PIPE BUT NOT LESS THAN 24"
7. THIS DETAIL DESCRIBES THE MINIMUM REQUIREMENTS FOR CUPERTINO SANITARY DISTRICT ONLY. ALL LOCAL AND COUNTY STANDARD SPECIFICATIONS MUST ALSO BE MET.

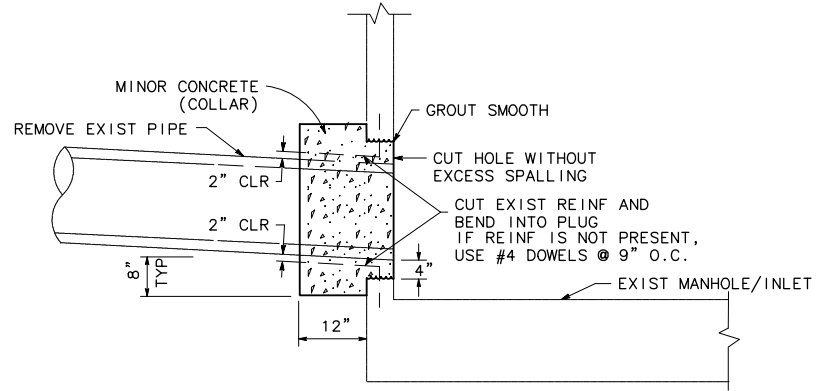

PLUG EXIST INLET
(NTS)

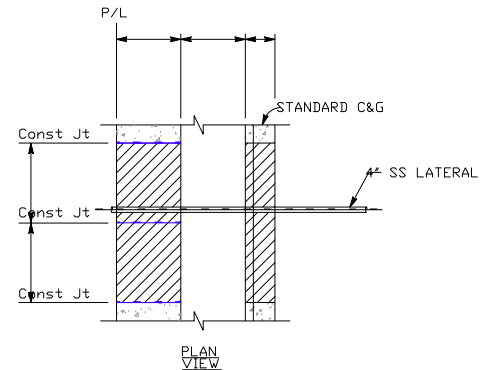
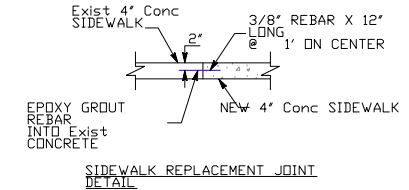

G TRENCH

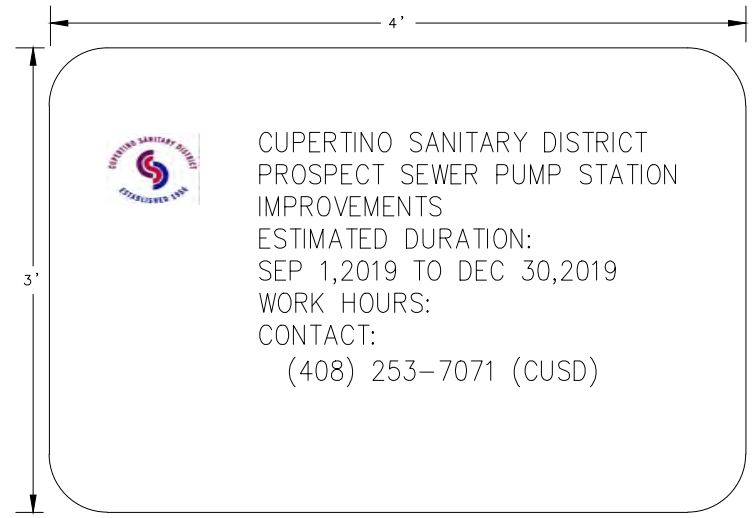

CUPERTINO SANITARY DISTRICT
PROSPECT SEWER PUMP STATION
IMPROVEMENTS
ESTIMATED DURATION:
SEP 1,2019 TO DEC 30,2019
WORK HOURS:
CONTACT:
(408) 253-7071 (CUSD)

- NOTES:**
1. SIGN TO BE MOUNTED ON TWO POSTS

J PROJECT SIGN

H CAP AT MAHOLES

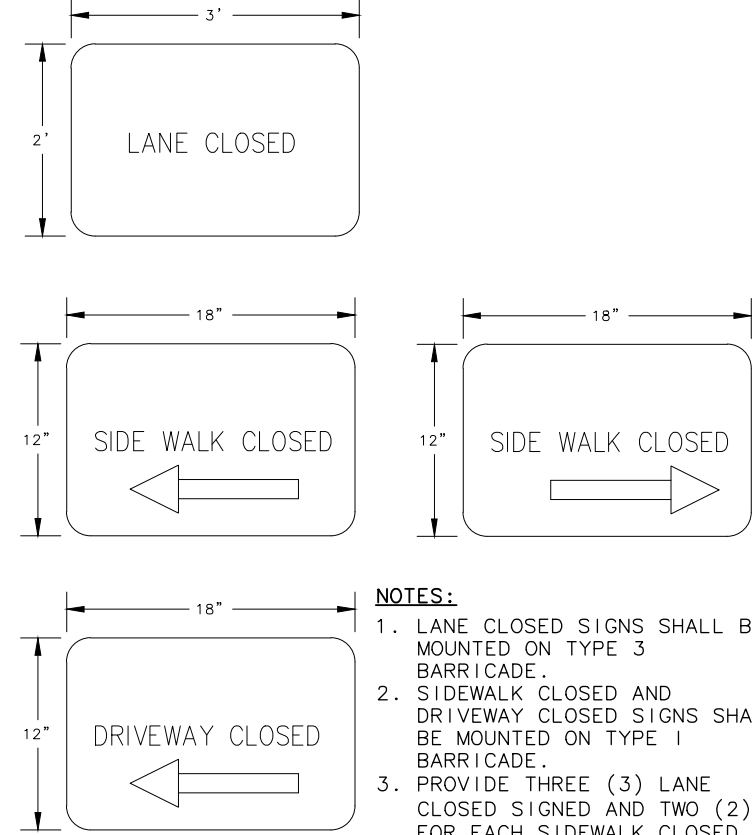

- NOTES:**
1. LANE CLOSED SIGNS SHALL BE MOUNTED ON TYPE 3 BARRICADE.
 2. SIDEWALK CLOSED AND DRIVEWAY CLOSED SIGNS SHALL BE MOUNTED ON TYPE 1 BARRICADE.
 3. PROVIDE THREE (3) LANE CLOSED SIGNED AND TWO (2) FOR EACH SIDEWALK CLOSED AND DRIVEWAY CLOSED.

K CONSTRUCTION SIGNS

I CURB REPLACEMENT

MARK THOMAS
20863 STEVENS CREEK BLVD, STE 100
CUPERTINO, CA 95014
(408) 255-2137

DESIGNED BY :	ED				
DRAWN BY :	JB				
CHECKED BY :	BP				
DATE :	9/8/2022				
SCALE :		No.	DESCRIPTION	DATE	BY
MTCO JOB No. :	CU-19104		REVISIONS		

CUPERTINO SANITARY DISTRICT
20863 STEVENS CREEK BOULEVARD, SUITE 100
CUPERTINO, CA 95014
(408) 255-2137 FAX (408) 253-5173

REGISTERED CIVIL ENGINEER _____ DATE _____

CUSD SIGNIFICANT DEFECT
REPAIR PROJECT
STANDARD DETAILS

WORK ORDER No. _____ ADVERTISEMENT DATE: _____ CONTRACT No. _____

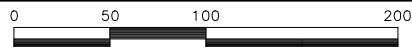

Graphic Scale

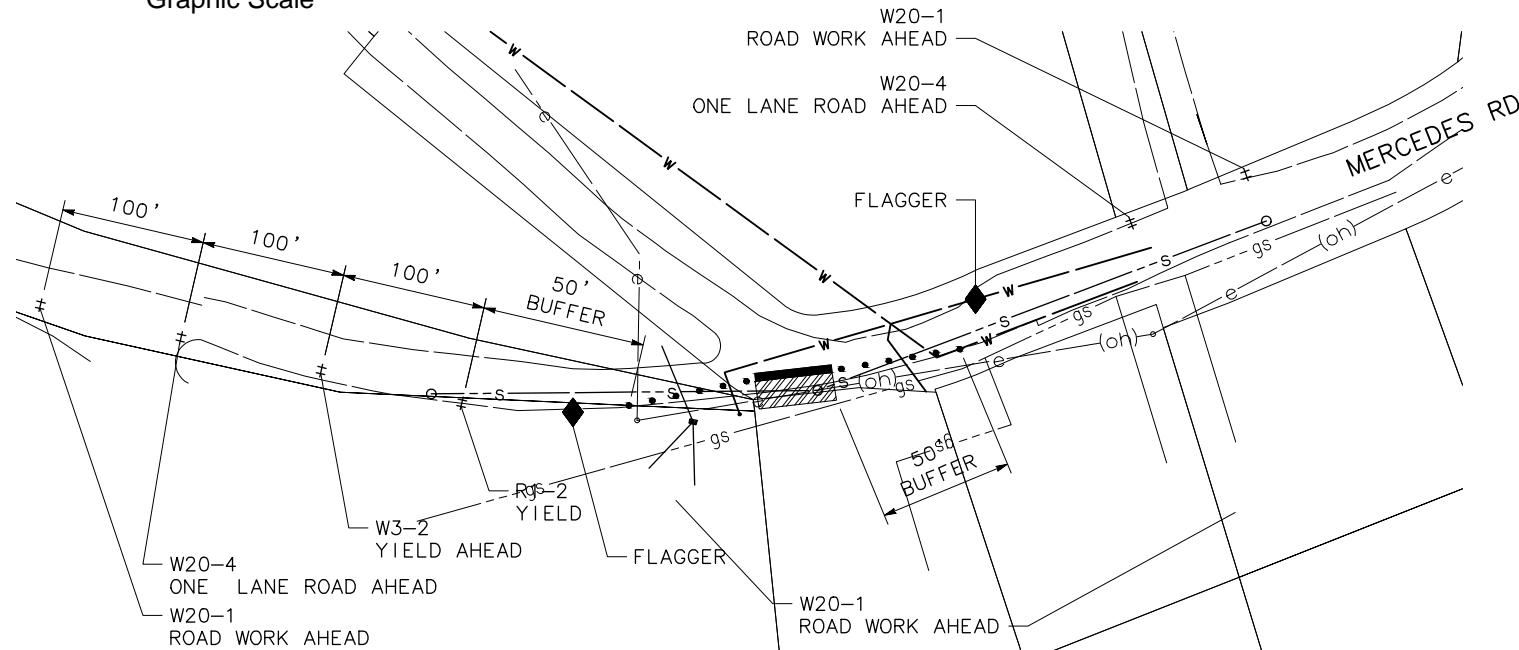

LANE CLOSURE ON A TWO-LANE ROAD WITH LOW TRAFFIC VOLUME

SCALE: NTS

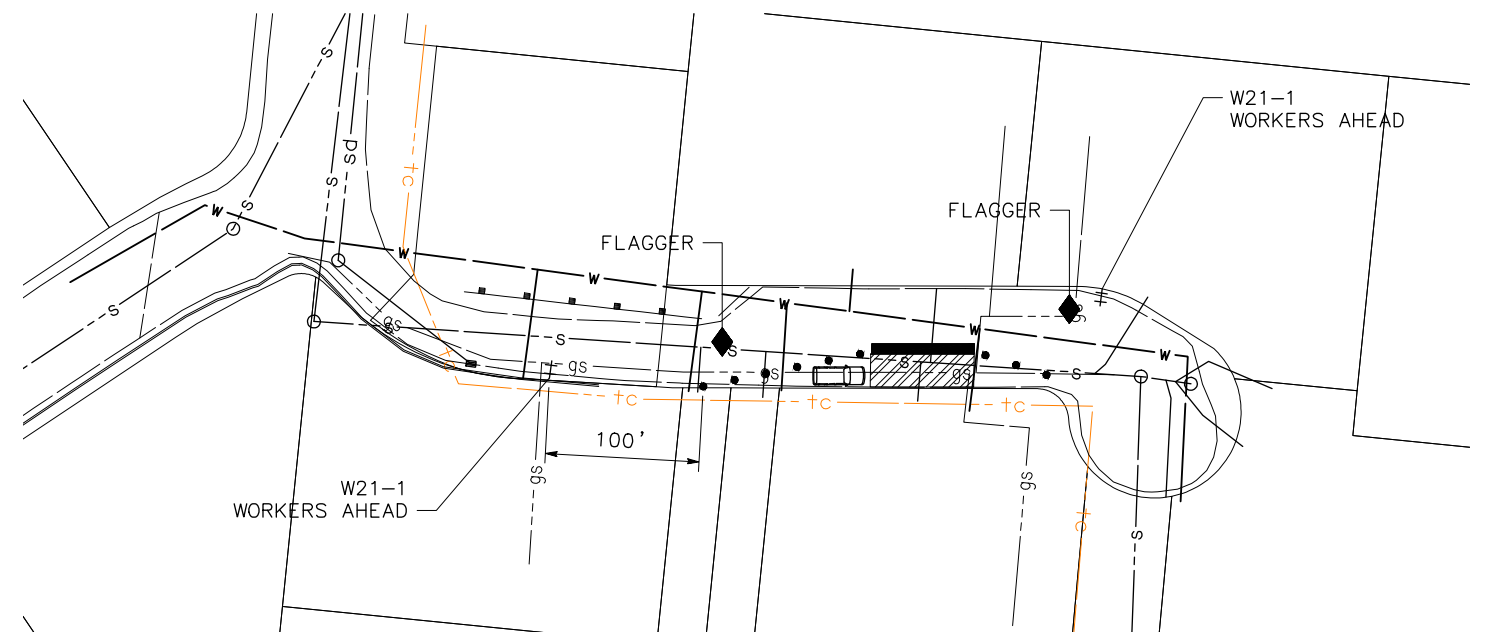

LANE CLOSURE ON A MINOR STREET

SCALE: NTS

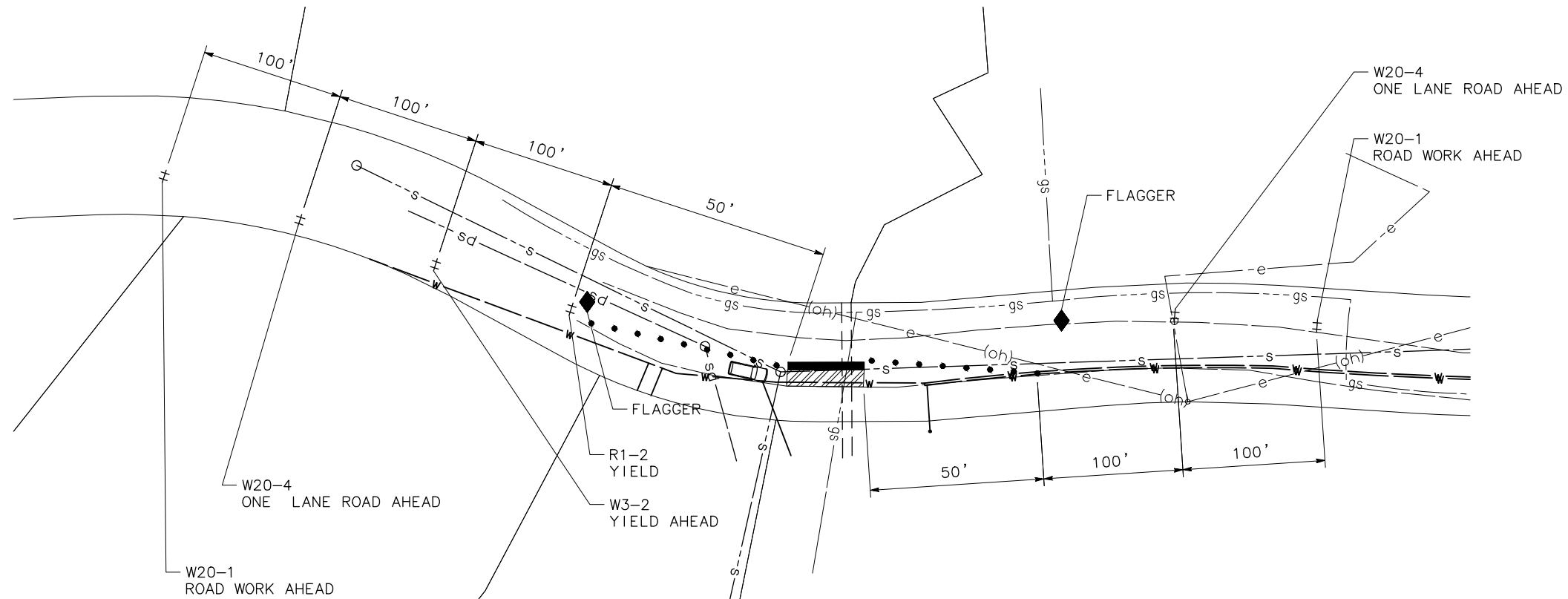

LANE CLOSURE ON TWO-LANE ROAD

SCALE: NTS



20863 STEVENS CREEK BLVD, STE 100
CUPERTINO, CA 95014
(408) 255-2137

DESIGNED BY :	ED				
DRAWN BY :	ED				
CHECKED BY :	IT				
DATE :	9/8/2022				
SCALE :	#####	No.	DESCRIPTION	DATE	BY
MTCo JOB No. : CU-13101		REVISIONS			



CUPERTINO SANITARY
20863 STEVENS CREEK BOULEVARD, SUITE 100
CUPERTINO, CA 95014
(408) 253-7071 FAX (408) 253-5173

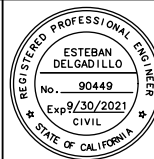

REGISTERED CIVIL ENGINEER

9/8/2022
DATE

WORK ORDER No.	ADVERTISEMENT DATE:	CONTRACT No.
----------------	---------------------	--------------

CUSD SIGNIFICANT DEFECT
REPAIR PROJECT
TRAFFIC CONTROL

SHEET
8
OF 8 SHEETS
TC-1

Fall Fun Festival-2022 Overview

CuSD participated in the annual Fall Fun Festival held in Cupertino on Saturday, September 24, 2022.

Despite the warm weather and the continued presence of COVID-19, there was good attendance at the event. In the utilities section of the festival, crowds came through in clusters throughout the day, with early morning and early afternoon being the busiest. It is estimated that the District booth had 200 visitors throughout the day.

The focus of our public outreach was to educate our customers on how to properly maintain the sewer system and prevent sewer backups. This year, a good number of visitors seemed educated about not flushing flushable wipes, even though it is labeled as flushable, and not pouring cooking grease down the drains. This suggests that our educational efforts from previous years have worked.

For our displays, we put out two large boards with the District Inflow and Infiltration Reduction Program and some visual examples and handouts to go along with it.

The following demos were also displayed:

Demo 1 was three glass jars filled with water. One jar had toilet paper, one jar had wipes labeled as “flushable” and the third jar had a baby wipe to show how toilet paper easily breaks down in water and how baby wipes and “flushable” wipes do not.

Demo 2 showed what cooking oil looks like in the sewer line. A piece of ABS pipe was coated inside with hot glue to replicate cooking oil buildup. This gave visitors a good visual idea of why it’s important not to flush oil and grease down the drain. Visitors were educated on the proper way to dispose of grease.

Outcome: Many booth visitors expressed how informative the information was and liked the visual demos. Many were aware of the effects of baby wipes and cooking grease in the sewer.

Approximately 150 mini travel kit (mirror & comb) and 150 sanitizer spray bottles were handed out to attendees with District logo. Snacks were also handed out to the children.





**CUPERTINO SANITARY DISTRICT
MEETING/EVENT SCHEDULE**

Item 12.A.

	OCTOBER 2022						
	Sunday	Monday	Tuesday	Wednesday	Thursday	Friday	Saturday
							1
10/05: 1 st Regular Meeting	2	3	4	5 1 st Regular Meeting	6 CASSE	7	8
10/06: CASSE							
10/10: TAC - CANCELED	9	10 TAC	11	12	13 TPAC	14	15
10/13: TPAC - CANCELED							
10/19: 2 nd Regular Meeting (Directors Bosworth and Kwok absent)	16	17	18	19 2 nd Regular Meeting	20	21	22
	23	24	25	26	27	28	29
	30	31					

	NOVEMBER 2022						
	Sunday	Monday	Tuesday	Wednesday	Thursday	Friday	Saturday
			1	2 1 st Regular Meeting	3	4	5
11/02: 1 st Regular Meeting - CANCELED	6	7 TAC	8	9	10 TPAC	11	12
11/07: TAC							
11/10: TPAC	13	14	15	16 2 nd Regular Meeting CASA CSW	17	18	19
11/16: 2 nd Regular Meeting							
11/16: CASA CSW	20	21	22	23	24 HOLIDAY	25	26
	27	28	29	30			

	DECEMBER 2022						
	Sunday	Monday	Tuesday	Wednesday	Thursday	Friday	Saturday
					1	2	3
12/05: TAC & SCCSDA	4	5 TAC SCCSDA	6	7 1 st Regular Meeting	8 TPAC	9	10
12/05: 1 st Regular Meeting							
12/08: TPAC	11	12	13	14	15	16	17
12/21: 2 nd Regular Meeting	18	19	20	21 2 nd Regular Meeting	22	23	24
	25 HOLIDAY	26	27	28	29	30	31